

DOM-FORCING SETS IN GRAPHS

ABSTRACT. A dominating set $D_f \subseteq V(G)$ of vertices in a graph G is called a *dom-forcing set* if the sub-graph induced by D_f must form a zero forcing set. The minimum cardinality of such a set is known as the dom-forcing number of the graph G , denoted by $F_d(G)$. This article embarks on an exploration of the dom-forcing number of a graph G . Additionally, it delves into the precise determination of $F_d(G)$ for certain well-known graphs.

AMS Subject Classification: 05C50,05C69.

Key Words: Zero forcing number, Domination number, Dom-forcing number.

1. INTRODUCTION

Zero forcing is a step-by-step coloring process where at every discrete time step, a black colored vertex with a single white-colored neighbor forces that white-colored neighbor to become colored black. A zero forcing set of a simple graph G is a set of initially colored black vertices that force the entire graph G to become colored black. The zero forcing number is the cardinality of the least zero forcing set. Zero Forcing on graphs was initiated in a workshop on linear algebra and graph theory organized by AIM in 2006 [1] and the concept was used to bound the minimum rank of a graph. The concept of zero-forcing was also used to study the quantum controllability of the system. Since its introduction, zero forcing number has been a topic of interest in graph theory and a plethora of research has been carried out in this regard [14-17]. Zero forcing number of graph and its complement is studied in [7], it is used to study

the logic circuit as well in [13].

A set $D \subseteq V$ of vertices in a graph $G = (V, E)$ is called a dominating set if every vertex $v \in V(G)$ is an element of D or is adjacent to an element of D . A set $D_f \subseteq V$ of vertices is called a *dom-forcing set* if it satisfies the following two conditions.

- i) D_f must form a dominating set.
- ii) D_f must form a zero forcing set.

The minimum cardinality of such a set is called the dom-forcing number of the graph G and is denoted by $F_d(G)$. For instance, contemplate the graph C_5 illustrated in Figure 1.

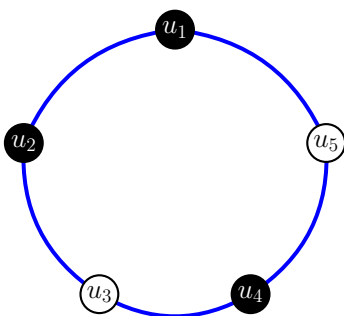

FIGURE 1. In this graph C_5 , $D_f = \{u_1, u_2, u_4\}$ is a dominating set as well as a zero forcing set and no subset of the vertex set with cardinality less than three has this property, so $F_d(C_5) = 3$

In this article, we combine the concepts of domination and zero forcing and study a new graph-theoretic parameter called dom-forcing sets in graphs.

Note 1.1. We use the letter Z to represent the zero forcing set. The zero forcing number of G is denoted by $Z(G)$ and the domination number of G is denoted by $\gamma(G)$.

2. MOTIVATION

The investigation of dom-forcing sets in graphs comes as a request to bring into one framework and generalize two fundamental notions in graph theory: domination and zero forcing. Both have been found to be good tools for graph modeling of control and influence within networks, but both describe different facets of the process. Domination is concerned with direct or local control—making every vertex either chosen or a neighbor of a chosen vertex—whereas zero forcing represents a dynamic process in which influence propagates according to certain rules. By blending these ideas, dom-forcing sets offer a more complete picture of both static and dynamic control in networks.

This combination is especially driven by applications in the real world in which influence has to be started and maintained over a system. For example, in power systems, starting sensors (domination) have to blanket the grid as well as facilitate cascading monitoring (forcing). In social networks, it may be the case that only a small group of influential actors needs to directly reach their neighbors, as well as start a more general chain effect of influence. Likewise, in biological systems or distributed computing, a connected and efficient spread of signals or information is crucial. dom-forcing sets provide a mathematical model for such dual demands for instant coverage and sustained propagation.

Theoretically, exploring dom-forcing sets provides a wide range of challenging problems. It provokes us to search for new bounds, connections to traditional parameters (like the domination number and the zero forcing number), and characterizations in graphs. It also prompts algorithms to find such sets in efficient time, something of direct relevance to areas of research such as network optimization, control theory, and distributed systems.

In total, the impetus behind this work comes from both the beautiful theoretical unification it embodies and the operational needs of contemporary networked systems. By filling the gap between static and dynamic control, controlling zero forcing sets provide a subtle tool with which to study and design systems that are influential yet robust.

3. BOUNDS FOR DOM-FORCING SETS

in this section, we discuss some bounds for the dom-forcing set. The definition makes it evident that the combination of a zero forcing set and a dominating set constitutes a dom-forcing set. Therefore, the following relationship holds:

Proposition 3.1. *For any connected graph G*

$$\begin{aligned} i) \quad & Z(G) \leq F_d(G) \leq Z(G) + \gamma(G) \\ ii) \quad & \gamma(G) \leq F_d(G) \leq Z(G) + \gamma(G) \end{aligned}$$

The following figure illustrates a graph where $Z(G) = \gamma(G) = F_d(G) = 2$.

Example 3.2. *The dom-forcing set and the dom-forcing number of the graph in the Figure 2 is $D_f = \{v_1, v_2\}$ and $F_d(G) = 2$.*

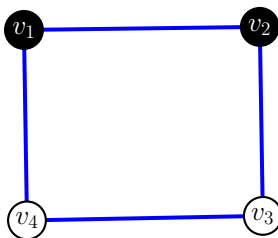

FIGURE 2. $G(V, E)$

Proposition 3.3. *Let $G = (V, E)$ be a graph and S be its minimum zero forcing set. Then $F_d(G) \leq Z(G) + \gamma(G - N[S])$.*

Proof. Let $G = (V, E)$ be a graph and S be its minimum zero forcing set. There exists a dominating set with cardinality $\gamma(G - N[S])$, say D , of $G - N[S]$. Then $S \cup D$ is a dom-forcing set of G . Therefore $F_d(G) \leq Z(G) + \gamma(G - N[S])$. \square

It can be seen that this bound is sharp for Paths, Cycles etc. This is illustrated in the Figure 3. In next section, we discussed the exact values of the dom-forcing number of some graphs.

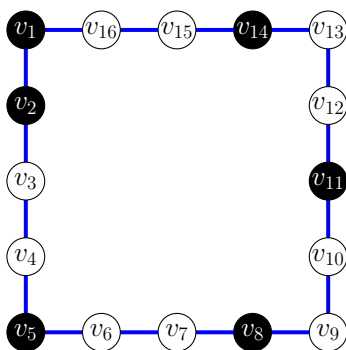

FIGURE 3. In the cycle C_{16} , $S = \{v_1, v_2\}$ will be a minimum zero forcing set and $G - N[S]$ is a path with vertex set $\{v_4, v_5, \dots, v_{15}\}$. $T = \{v_5, v_8, v_{11}, v_{14}\}$ will be a minimum dominating set of $G - N[S]$, therefore $\gamma(G - N[S]) = 4$. Hence $S \cup T$ is a dom-forcing set of C_{16} , which is minimum. Hence $F_d(C_{16}) = 6$.

4. EXACT VALUES OF $F_d(G)$

In this section, precise values of the dom-forcing number for several renowned graphs are investigated. We start with a path P_n .

Theorem 4.1. [5, 6] *For a path P_n , $\gamma(P_n) = \lceil n/3 \rceil$ and $Z(P_n) = 1$.*

Example 4.2. *Consider the graphs given in Figure 4. For P_3 , $D_f = \{v_1, v_3\}$ and $F_d = 2$. For P_4 , $D_f = \{u_1, u_4\}$ and $F_d = 2$. We can generalize this result.*

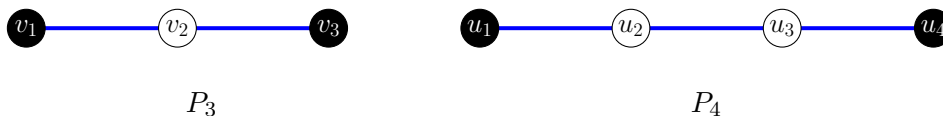

FIGURE 4. Dom-forcing set for P_3 and P_4

Theorem 4.3. *For a path P_n , $F_d(P_n) = \lfloor n/3 \rfloor + 1$.*

Proof. Consider a path P_n , with $V(P_n) = \{v_1, v_2, \dots, v_n\}$. For $i = 2, 3, \dots, n-1$ each vertex v_i is adjacent with v_{i-1} and v_{i+1} . It can be easily observed that $F_d(P_1) = F_d(P_2) = 1$. For $n \geq 3$, consider the following cases and the following subset of $V(P_n)$.

Case 1: Assume $n \equiv 0, 1 \pmod 3$, $D_f = \{v_{3k+1}, v_n\}$ where $0 \leq k < \lfloor n/3 \rfloor$.

Case 2: Assume $n \equiv 2 \pmod 3$, $D_f = \{v_{3k+1}, v_{n-1}\}$ where $0 \leq k < \lfloor n/3 \rfloor$.

In both cases D_f contains one of the end vertices, hence it forces P_n . Also, it dominates P_n . Therefore, the set D_f is a dom-forcing set for P_n . Any pendant vertex or two adjacent vertices forces P_n , and no set with cardinality less than $|D_f|$ have this property. Therefore, $F_d(P_n) = \lfloor n/3 \rfloor + 1$. \square

We can find the following observation in [20].

Observation 4.4. [20] *For any connected graph $G = (V; E)$, $Z(G) = 1$ if and only if $G = P_n$.*

Theorem 4.5. *For any graph G , $F_d(G) = 1$ if and only if $G = P_1$ or P_2 .*

Proof. For $G = P_1$ or P_2 , by the Theorem 4.3, $F_d(G) = 1$. Conversely suppose that $F_d(G) = 1$. Then $Z(G) = \gamma(G) = 1$. But by Observation 4.4, $Z(G) = 1$ implies that G is a path, also from the Theorem 4.3, $G = P_1$ or P_2 . \square

Now let us examine the dom-forcing number of cycle graph C_n .

Theorem 4.6. [5, 6] *For a cycle C_n , of order $n \geq 3$, $Z(C_n) = 2$ and $\gamma(C_n) = \lfloor n/3 \rfloor$.*

Theorem 4.7. *For cycle C_n , $n \geq 3$*

$$F_d(C_n) = \begin{cases} \lfloor n/3 \rfloor + 1 & \text{if } n \equiv 0, 1 \pmod 3 \\ \lfloor n/3 \rfloor + 2 & \text{if } n \equiv 2 \pmod 3 \end{cases}$$

Proof. Let C_n be a cycle with vertices v_1, v_2, \dots, v_n . Consider the following cases and the following subset of $V(C_n)$.

Case 1: Assume $n \equiv 0, 1 \pmod 3$, $D_f = \{v_{3k+1}, v_n\}$, where $0 \leq k < \lfloor n/3 \rfloor$.

Case 2: Assume $n \equiv 2 \pmod 3$, $D_f = \{v_{3k+1}, v_{n-1}, v_n\}$, where $0 \leq k < \lfloor n/3 \rfloor$.

In both cases, D_f contains two adjacent vertices, hence it forces C_n . Also for $i = 2, 3, \dots, n-1$, each vertex v_i is adjacent with v_{i-1} and v_{i+1} , D_f dominates C_n . Therefore, D_f is a dom-forcing set. Any pair of adjacent vertices can force the cycle graph C_n . Moreover, no set with cardinality smaller than $|D_f|$ possesses this forcing property. Hence

$$F_d(C_n) = \begin{cases} \lfloor n/3 \rfloor + 1 & \text{if } n \equiv 0, 1 \pmod 3 \\ \lfloor n/3 \rfloor + 2 & \text{if } n \equiv 2 \pmod 3 \end{cases}$$

\square

The ladder graph L_n is the graph obtained by taking the Cartesian product of P_n with P_2 .

Theorem 4.8. [6] *For a ladder graph L_n , $n \geq 2$, $Z(L_n) = 2$.*

Theorem 4.9. [18] *For a ladder graph L_n , $n \geq 2$, $\gamma(L_n) = \lfloor \frac{n}{2} \rfloor + 1$.*

Theorem 4.10. For $n \geq 2$, let L_n denote the Ladder graph, then $F_d(L_n) = \lceil \frac{n}{2} \rceil + 1$.

Proof. Let $\{u_1, u_2, \dots, u_n, v_1, v_2, \dots, v_n\}$ be the vertices of the ladder graph L_n . For the ladder graphs L_1, L_2, L_3 and L_4 , the subset of vertices $\{u_1\}, \{u_1, u_2\}, \{u_1, u_2, v_3\}$ and $\{u_1, u_2, v_4\}$ respectively constitute a dom forcing set. And for $n > 4$, consider the following cases and the following subsets of vertex sets.

Case 1: Assume that $\lceil \frac{n}{2} \rceil$ is odd, consider

$$D_f = \{u_1, u_{4k-2}, v_{4k}, u_n\} \text{ for } 1 \leq k < \lceil n/4 \rceil$$

Case 2: Assume $\lceil \frac{n}{2} \rceil$ is even, consider

$$D_f = \{u_1, u_2, v_{4k}, u_{4k+2}, v_n\} \text{ for } 1 \leq k < \lceil n/4 \rceil.$$

Now D_f forms a dom-forcing set. It can be easily verified that no set with less than $|D_f|$ vertices cannot form a dom-forcing set, hence $F_d(L_n) = \lceil \frac{n}{2} \rceil + 1$. \square

A coconut tree graph $CT(m, n)$ is the graph obtained from the path P_m by appending ‘ n ’ new pendant edges at an end vertex of P_m .

Theorem 4.11 ([11]). For any coconut tree graph $CT(m, n)$, the domination number is $1 + \lceil \frac{m-2}{3} \rceil$, where $m \geq 1, n \geq 1$.

Theorem 4.12. For any coconut tree graph $CT(m, n)$, the zero forcing number is n , where $m \geq 1, n \geq 1$.

Proof. Let $v_1, v_2, \dots, v_m, u_1, u_2, \dots, u_n$ be the vertices of $CT(m, n)$, then $\{u_1, u_2, \dots, u_n\}$ forms a zero forcing set. Which is minimum since $CT(m, n)$ contains a star graph of $n + 2$ vertices. \square

Theorem 4.13. For any coconut tree $CT(m, n)$, the dom-forcing number is $n + \lceil \frac{m-1}{3} \rceil$, where $m \geq 1, n \geq 1$.

Proof. Let $v_1, v_2, \dots, v_m, u_1, u_2, \dots, u_n$ be the vertices of $CT(m, n)$. Then $\{u_1, u_2, \dots, u_n\}$ forms a minimum zero forcing set.

Case 1: Assume $n = 0, 1 \pmod 3$, $D_f = \{u_1, u_2, \dots, u_n, v_{3k}\}$, where $0 < k \leq \lfloor m/3 \rfloor$.

Case 2: Assume $n = 2 \pmod 3$, $D_f = \{u_1, u_2, \dots, u_n, v_{3k}, v_n\}$, where $0 < k \leq \lfloor m/3 \rfloor$.

In both cases D_f is a dom-forcing set. No set with cardinality less than $|D_f|$ have this property. Therefore, $F_d(CT(m, n)) = n + \lceil \frac{m-1}{3} \rceil$. \square

There are graphs having $Z(G) = \gamma(G)$, but its dom-forcing number is larger than $Z(G)$. For example, a diamond snake graph D_n is a connected graph obtained from a path P of length n with each edge $e = (u, v)$ in P replaced by a cycle of length 4 with u and v as nonadjacent vertices of the cycle. For any diamond snake graph, $Z(D_n) = \gamma(D_n) = n + 1$ [16, 11].

Theorem 4.14. For diamond snake graph

$$F_d(D_n) = \begin{cases} \frac{3n}{2} & \text{if } n \text{ is even} \\ \frac{3n+1}{2} & \text{if } n \text{ is odd.} \end{cases}$$

Proof. Let $u_1, \dots, u_n, v_1, \dots, v_{n+1}, w_1, \dots, w_n$ be the vertices of diamond snake graph D_n (see Figure 5). Consider the following cases and the following subset of the vertex set of D_n .

Case 1: Assume n is even, $D_f = \{u_1, \dots, u_n, v_{2k}\}$, where $1 \leq k \leq \frac{n}{2}$.

Case 2: Assume n is odd, $D_f = \{u_1, \dots, u_n, v_{2k}\}$, where $1 \leq k \leq \frac{n+1}{2}$.

Now D_f forms a dom-forcing set. It can be easily verified that no set with less than $|D_f|$ vertices forms a dom-forcing set. Therefore,

$$F_d(D_n) = \begin{cases} \frac{3n}{2} & \text{if } n \text{ is even} \\ \frac{3n+1}{2} & \text{if } n \text{ is odd.} \end{cases}$$

□

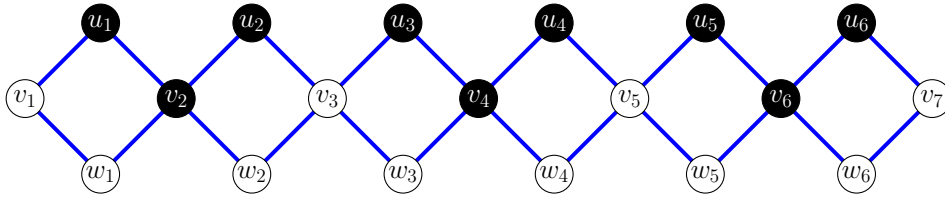

FIGURE 5. The Diamond Snake Graph D_6 . Dom-forcing set $D_f = \{u_1, u_2, \dots, u_6, v_2, v_4, v_6\}$ and $F_d(D_6) = 9$

5. EXACT VALUES OF DOM-FORCING NUMBER OF GRAPHS WHERE $Z(G) = F_d(G)$

There are graphs having the same dom-forcing number and the zero-forcing number. For example, consider the triangular snake graph, denoted by, TS_n , obtained from a path P_{n+1} by replacing each edge of the path by a triangle C_3 [17].

Theorem 5.1. [17] For a triangular snake graph TS_n , $Z(TS_n) = n + 1$.

Theorem 5.2. For a triangular snake graph TS_n , $F_d(TS_n) = Z(TS_n) = n + 1$.

Proof. Let $v_1, v_2, \dots, v_{n+1}, u_1, u_2, \dots, u_n$ be the vertices of the triangular snake graph TS_n (see Figure 6). $D_f = \{v_1, u_1, u_2, \dots, u_n\}$ forms a dom-forcing set, which is minimum since $Z(TS_n) = n+1$. Therefore, $F_d(TS_n) = Z(TS_n) = n+1$.

□

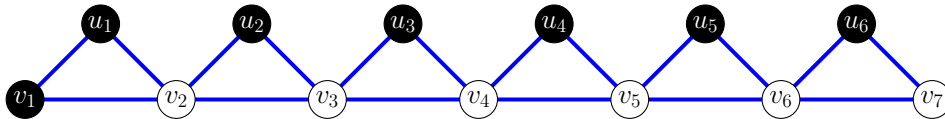

FIGURE 6. The triangular snake graph TS_6 , dom-forcing set $D_f = \{v_1, u_1, u_2, \dots, u_6\}$ and $F_d(TS_6) = 7$

A hypercube of dimension k , represented by Q_k , has vertex set $\{0, 1\}^k$, with vertices adjacent when they differ in exactly one coordinate. Or, the constructive definition:

Let Q_0 be a single vertex. For $k \geq 1$, Q_k is formed by taking two copies of Q_{k-1} and adding a matching joining the corresponding vertices in the two copies. This is equivalent to taking the Cartesian product of Q_{k-1} and K_2 to form Q_k [22]. Zero forcing number of hypercube graph Q_k is 2^{k-1} [1].

Theorem 5.3. *For a hypercube graph Q_k , $F_d(Q_k) = Z(Q_k) = 2^{k-1}$.*

Proof. The set of all vertices having first coordinate zero (all vertices of Q_{k-1}) forms a zero forcing set with cardinality 2^{k-1} . Clearly, it dominates Q_k (see figure 7). Hence $F_d(Q_k) = Z(Q_k) = 2^{k-1}$. \square

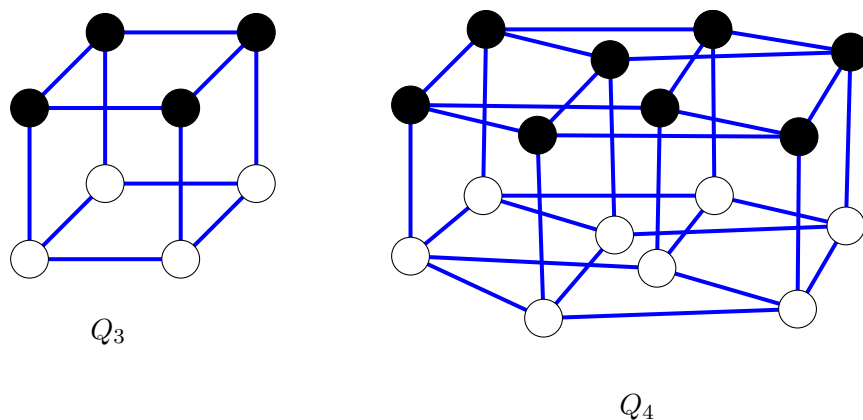

FIGURE 7. Dom-forcing (and zero forcing) in hypercube graphs Q_3 and Q_4

Theorem 5.4. *Let G be a graph with n vertices and $\Delta(G) = n - 1$. Then $Z(G) \leq F_d(G) \leq Z(G) + 1$.*

Proof. Let v be the vertex of G having degree $n - 1$. If the minimum zero forcing set S contains v , then $Z(G) = F_d(G)$. Otherwise, $S \cup \{v\}$ forms a dom-forcing set. \square

By using Theorem 5.4, we can easily verify the following results.

Theorem 5.5. *For a complete graph K_n , $Z(K_n) = F_d(K_n) = n - 1$.*

The wheel graph, W_n , is a graph obtained by connecting a single vertex to all vertices of a cycle graph C_{n-1} .

Theorem 5.6. *For wheel graph W_n , $Z(W_n) = F_d(W_n) = 3$.*

The dove tail graph, DT_n , is the graph $P_n + K_1, n \geq 2$. The dove tail graph has $n + 1$ vertices and $2n - 1$ edges [21].

Theorem 5.7. *Let DT_n denote the dove tail graph. Then, $Z(DT_n) = F_d(DT_n) = 2$.*

In the case of complete bipartite graph every zero forcing set dominates the entire graph and hence we have the following result.

Theorem 5.8. *Let $K_{m,n}$ denote the complete bipartite where $n, m \geq 2$. Then $\mathcal{Z}(K_{m,n}) = F_d(K_{m,n}) = m + n - 2$.*

From Theorems 4.1, 4.3, 4.6 and 4.7 we have the following observations.

Observation 5.9. *For a path P_n and a cycle C_n ,*

- $\mathcal{Z}(P_n) = F_d(P_n)$ if and only if $n = 1$ or 2 .
- $\mathcal{Z}(C_n) = F_d(C_n)$ if and only if $n = 3$ or 4 .

Theorem 5.10. [6] *For the star graph $K_{1,n}$, $\gamma(K_{1,n}) = 1$ and $\mathcal{Z}(K_{1,n}) = n - 1$, for $n \geq 2$.*

Theorem 5.11. *For the star graph $K_{1,n}$, $F_d(K_{1,n}) = n$, for $n \geq 2$.*

Proof. We know that the star graph $K_{1,n}$ have n vertices of degree 1 and one vertex of degree n . Any minimum zero forcing set does not contain the vertex of degree n , and $\mathcal{Z}(K_{1,n}) = n - 1$. Therefore by Theorem 5.4, $F_d(K_{1,n}) = n$. \square

The pineapple graph, denoted by K_m^n , is the graph formed by coalescing any vertex of the complete graph K_m with the star graph $K_{1,n}$, ($m \geq 3, n \geq 2$). The number of vertices in K_m^n is $m + n$ and the number of edges in K_m^n is $\frac{m^2 - m + 2n}{2}$ [19].

Theorem 5.12. *Let G be the pineapple graph K_m^n with $n \geq 2, m \geq 3$. Then $F_d(G) = m + n - 2$.*

Proof. We know that the pineapple graph comprises $m + n$ vertices. In [16], the zero forcing number of the pineapple graph is $m + n - 3$, when $n \geq 2, m \geq 3$. Pineapple graph has a vertex v with degree $m + n - 1$, and the vertex v does not belong to any minimum zero forcing set. Therefore by Theorem 5.4, $F_d(G) = m + n - 3 + 1 = m + n - 2$. \square

Definition 5.13. [24] Let $G = (V, E)$ be a graph and B a zero forcing set of G . Define $B^{(0)} = B$, and for $t \geq 0$, $B^{(t+1)}$ is the set of vertices w for which there exists a vertex $b \in \bigcup_{s=0}^t B^{(s)}$ such that w is the only neighbor of b not in $\bigcup_{s=0}^t B^{(s)}$. The propagation time of B in G , denoted $pt(G, B)$, is the smallest integer t_0 such that $V = \bigcup_{s=0}^{t_0} B^{(s)}$. Two minimum zero forcing sets of the same graph may have different propagation times. The minimum propagation time of G is

$$pt(G) = \min\{pt(G, B) \mid B \text{ is a minimum zero forcing set of } G\}.$$

Example 5.14. *Let G be the graph in Figure 8. Let $B_1 = \{v_1, v_2\}$ and $B_2 = \{v_5, v_8\}$. Then $B_1^{(1)} = \{v_3, v_6\}$, $B_1^{(2)} = \{v_4\}$, $B_1^{(3)} = \{v_5\}$, $B_1^{(4)} = \{v_7\}$, and $B_1^{(5)} = \{v_8\}$, so $pt(G, B_1) = 5$. However $B_2^{(1)} = \{v_7\}$, $B_2^{(2)} = \{v_6\}$, $B_2^{(3)} = \{v_1, v_4\}$, and $B_2^{(4)} = \{v_2, v_3\}$, so $pt(G, B_2) = 4$.*

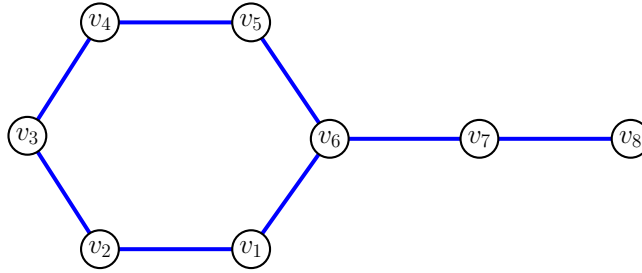

FIGURE 8. Graph for Example 5.14.

Theorem 5.15. *Let $G = (V, E)$ be a graph with minimum propagation time one. Then, $F_d(G) = \mathcal{Z}(G)$.*

Proof. From the definition of minimum propagation time, there exist a minimum zero forcing set B such that $V = B \cup B^{(1)}$. Every vertex of $B^{(1)}$ is adjacent to some vertex in B , so B dominates G . Hence B is a dom-forcing set which is minimum. \square

The converse of the above theorem is false. For example, let G be the wheel graph with six vertices. Then $F_d(G) = \mathcal{Z}(G)$, but minimum propagation time 2.

Theorem 5.16. *Let P denote the Petersen graph shown in Figure 9. Then, $F_d(P) = 5 = \mathcal{Z}(P)$.*

Proof. The minimum propagation time of the Petersen graph is one and minimum zero forcing number is five [1]. Hence by theorem 5.15, we have the result.

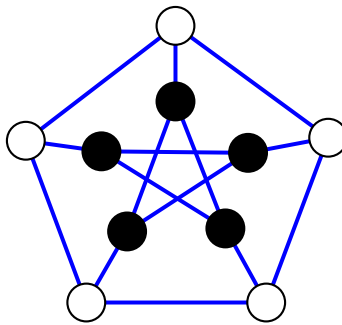

FIGURE 9. Dom-forcing set and zero forcing set for the Petersen graph.

\square

6. GRAPHS WHERE $\gamma(G) = F_d(G)$

There are some graphs with $\gamma(G) = F_d(G)$. For example, a helm graph is a graph that is created by attaching a pendant edge to each vertex of an n -wheel graph's cycle, and is denoted by H_m , where $m \geq 4$ [12].

Theorem 6.1. [12] Let H_m denote the helm graph. Then the domination number of graph H_m is m .

Theorem 6.2. The dom-forcing number of helm graph H_m is m . ie $F_d(H_m) = m = \gamma(H_m)$.

Proof. Let v_0 denote the vertex in helm graph such that its degree is equal to m , and let v_1, v_2, \dots, v_m represent the vertices in the helm graph, each with a degree of 3. Also u_1, u_2, \dots, u_m represent the pendant vertices of the helm graph H_m (See Figure 10). It can be easily verified that $D_f = \{v_1, u_2, u_3, \dots, u_m\}$ is a dom-forcing set of H_m , which is minimum since $\gamma(H_m) = m$. Therefore, $F_d(H_m) = m = \gamma(H_m)$.

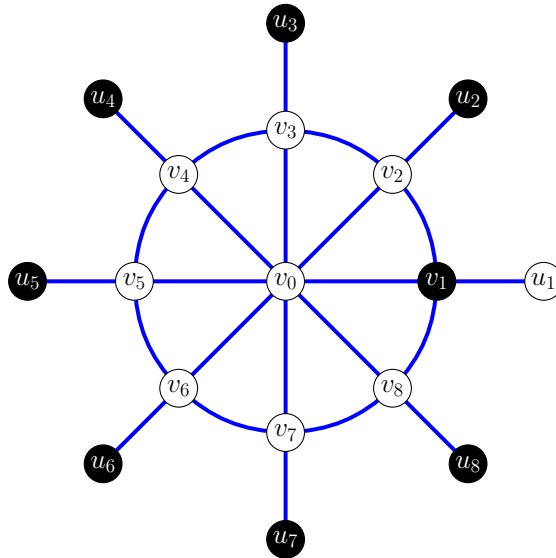

FIGURE 10. The Helm graph H_8 , dom-forcing set $D_f = \{v_1, u_2, u_3, \dots, u_8\}$ and $F_d(H_8) = 8$.

□

From Theorem 4.1, 4.3, 4.6 and 4.7, we can easily derive the following results

Theorem 6.3. For any path P_n , $F_d(P_n) = \gamma(P_n)$ if and only if n is not a multiple of three.

Theorem 6.4. For any cycle C_n , $F_d(C_n) = \gamma(C_n)$ if and only if $n = 3k + 1$, where k is any positive integer.

7. DOM-FORCING NUMBER OF SPLITTING GRAPH OF A GRAPH G

The splitting graph of a graph G is the graph $S(G)$ obtained by taking a vertex v' corresponding to each vertex $v \in G$ and join v' to all vertices of G adjacent to v [25].

Theorem 7.1. Let G be a connected graph of order $n > 1$ and $S(G)$ be its splitting graph. Then, $F_d[S(G)] \leq 2F_d(G)$.

Proof. Consider any minimum dom-forcing set D_f of G . Let $D_f = \{v_1, v_2, \dots, v_k\}$ for $1 \leq k < n$ be a minimum zero forcing set of G . Now consider the set $D'_f = \{v_1, v_2, \dots, v_k\} \cup \{u_1, u_2, \dots, u_k\}$, where u_1, u_2, \dots, u_k are vertices corresponding to v_1, v_2, \dots, v_k which are added to obtain $S(G)$. As in [6], D'_f forces $S(G)$. From the definition of splitting graph $N(u_1, u_2, \dots, u_k) = N(D_f)$, where $N(D_f)$ denotes the vertices which are adjacent to $\{v_1, v_2, \dots, v_k\}$, and $N[v_1, v_2, \dots, v_k] = V(S(G)) - \{u_1, u_2, \dots, u_k\}$. Hence D'_f dominates $S(G)$, it is a dom-forcing set. Therefore, $F_d[S(G)] \leq 2F_d(G)$. \square

Definition 7.2. [14] Given a graph $G = (V, E)$, a path cover is a set of disjoint induced paths in G such that every vertex $v \in V$ belongs to exactly one path. The path cover number $P(G)$ is the minimum number of paths in a path cover.

Theorem 7.3. [14] Let G be a graph. If $X \subset V(G)$ is a zero forcing set for G , then X induces a path cover for G and $P(G) \leq \mathcal{Z}(G)$.

Theorem 7.4. [8, 6] Let $S(P_n)$ denote the splitting graph of the path P_n .

Then, $\mathcal{Z}[S(P_n)] = 2\mathcal{Z}(P_n) = 2$ and $\gamma[S(P_n)] = \begin{cases} \frac{n}{2} & \text{if } n \equiv 0 \pmod{4} \\ \frac{n+1}{2} & \text{if } n \equiv 1, 3 \pmod{4} \\ \frac{n+2}{2} & \text{if } n \equiv 2 \pmod{4} \end{cases}$.

Theorem 7.5. Let $S(P_n)$ denote the splitting graph of the path P_n . Then for $2 \leq n \leq 4$, $F_d[S(P_n)] = n$.

Proof. Let v_1, v_2, \dots, v_n be the vertices of the graph P_n and u_1, u_2, \dots, u_n be the vertices corresponding to v_1, v_2, \dots, v_n which are added to obtain $S(P_n)$. Depending upon the number of vertices of P_n , we consider the following subsets of the vertex set of $S(P_n)$.

For $S(P_2)$, $D_f = \{u_1, v_1\}$, for $S(P_3)$, $D_f = \{u_1, v_1, v_2\}$, D_f forms a dom-forcing set which is minimum. For $S(P_4)$, $D_f = \{u_1, v_1, v_4, u_4\}$ forms a dom-forcing set, therefore $F_d[S(P_4)] \leq 4$. The domination number of $S(P_4)$ is 2. Hence $2 \leq F_d[S(P_4)]$. Let $A = \{v_2, v_3\}$ be a minimum dominating set of $S(P_4)$. Then $S(P_4) - A$ has four components (two components contains only single vertex and two of them is a path of length one), hence the set A cannot induces a path cover for $S(P_4)$. Hence $F_d[S(P_4)]$ cannot be 2. We claim the following

Claim 7.6. Any dominating set of cardinality 3 must contain A .

Proof of the Claim: If possible assume that there exists a dominating set D of $S(P_4)$ which does not contain A and the cardinality of D is 3. In $S(P_4)$, $\deg(u_1) = \deg(u_4) = 1$, and v_2, v_3 be the vertices having degree 4. All other vertices are of degree 2. Then consider the following cases.

Case 1: D contains a vertex of degree 4.

Then D must contain any one of the pendant vertices and the remaining non-dominating vertices are of degree two and which are non-adjacent. Hence we cannot form a dominating set of cardinality 3.

Case 2: D cannot contain a vertex of degree 4

Then D must contain the pendant vertices u_1, u_4 , and all other vertices are of degree two. Hence we cannot form a dominating set of cardinality 3.

In both cases we get a contradiction, hence our assumption is wrong, and the

claim is proved.

By the above claim $F_d[S(P_4)]$ cannot be 3. Therefore, we have $F_d[S(P_4)] = 4$. That is

$$F_d[(S(P_n))] = n, \text{ for } 2 \leq n \leq 4.$$

□

Let us now consider the case where the number of vertices in the splitting graph of the path is ≥ 5 .

Theorem 7.7. *For $n \geq 5$, let $S(P_n)$ be the splitting graph of the path P_n . Then*

$$\begin{aligned} \frac{n+2}{2} \leq F_d[(S(P_n))] &\leq \frac{n+4}{2} && \text{if } n \equiv 0 \pmod{4} \\ F_d[(S(P_n))] &= \frac{n+3}{2} && \text{if } n \equiv 1, 3 \pmod{4} \\ F_d[(S(P_n))] &= \frac{n+2}{2} && \text{if } n \equiv 2 \pmod{4}. \end{aligned}$$

Proof. Let v_1, v_2, \dots, v_n be the vertices of the graph P_n and u_1, u_2, \dots, u_n be the vertices corresponding to v_1, v_2, \dots, v_n which are added to obtain $S(P_n)$. At least one vertex from each pair u_1, v_2 and u_n, v_{n-1} belong to any dominating set, since $N(u_1) = \{v_2\}$ and $N(u_n) = \{v_{n-1}\}$. Also at least one vertex from v_{i-1}, v_{i+1} belongs to the dominating set, since $N(u_i) = \{v_{i-1}, v_{i+1}\}$ and $N(v_i) = \{v_{i-1}, v_{i+1}, u_{i-1}, u_{i+1}\}$. Thus any dominating set contains at least $\frac{n}{2}$ number of vertices. The set $\{v_1, u_1\}$ forces $S(P_n)$. Now depending upon the number of vertices of P_n , we consider the following subsets of the vertex set of $S(P_n)$.

For $n \geq 5$, consider the following cases.

Case 1: Assume $n \equiv 0 \pmod{4}$, $D_f = \{u_1, v_1, v_{4k}, v_{4k+1}, v_n, u_n\}$ where $0 < k < \lceil \frac{n}{4} \rceil$ forms a dom-forcing set, therefore $F_d[S(P_n)] \leq \frac{n+4}{2}$. The domination number of $S(P_n)$ is $\frac{n}{2}$. Hence $\frac{n}{2} \leq F_d[S(P_n)]$. Let A be a minimum dominating set of $S(P_n)$. Then $S(P_n) - A$ has $3 + \frac{n}{4}$ components (two components contain only a single vertex, two of them is the path of length one and $\frac{n}{4} - 1$ components having six vertices which include four pendant vertices), the set A cannot induce a path cover for $S(P_n)$. Hence $F_d[S(P_n)]$ cannot be $\frac{n}{2}$. Therefore, we have $\frac{n+2}{2} \leq F_d[S(P_n)] \leq \frac{n+4}{2}$.

Case 2: Assume $n \equiv 1, 2 \pmod{4}$, $D_f = \{u_1, v_1, v_{4k}, v_{4k+1}\}$ where $0 < k < \lceil \frac{n}{4} \rceil$, forms a dom-forcing set, therefore

$$F_d[S(P_n)] \leq \begin{cases} \frac{n+3}{2} & \text{if } n \equiv 1 \pmod{4} \\ \frac{n+2}{2} & \text{if } n \equiv 2 \pmod{4}. \end{cases}$$

If $n \equiv 2 \pmod{4}$, then the domination number of $S(P_n)$ is $\frac{n+2}{2}$. Hence $F_d[S(P_n)] = \frac{n+2}{2} = |D_f|$. If $n \equiv 1 \pmod{4}$, then the domination number of $S(P_n)$ is $\frac{n+1}{2}$. Hence $F_d[S(P_n)] \geq \frac{n+1}{2}$. Let A be a minimum dominating set of $S(P_n)$. Then $S(P_n) - A$ has $4 + \frac{n-1}{4}$ components (three components contain only a single vertex, two of them are paths of length one and $\frac{n-1}{4} - 1$ components having six vertices which include four pendant vertices), the set A cannot induce a path cover for $S(P_n)$. Hence $F_d[S(P_n)]$ cannot be $\frac{n+1}{2}$. Therefore, $F_d[S(P_n)] = \frac{n+3}{2}$.

Case 3: Assume $n \equiv 3 \pmod 4$, $D_f = \{u_1, v_1, v_{4k}, v_{4k+1}, v_{n-1}\}$ where $0 < k < \lceil \frac{n}{4} \rceil$ form a dom-forcing set, therefore $F_d[S(P_n)] \leq \frac{n+3}{2}$. The domination number of $S(P_n)$ is $\frac{n+1}{2}$. Hence $F_d[S(P_n)] \geq \frac{n+1}{2}$. Let A be a minimum dominating set of $S(P_n)$. Then $S(P_n) - A$ has at least $3 + \frac{n-3}{4}$ components, the set A cannot induce a path cover for $S(P_n)$. Hence $F_d[S(P_n)]$ cannot be $\frac{n+1}{2}$. Therefore, $F_d[S(P_n)] = \frac{n+3}{2}$.

From all the cases we have, for $n \geq 5$,

$$\begin{aligned} \frac{n+2}{2} \leq F_d[S(P_n)] &\leq \frac{n+4}{2} && \text{if } n \equiv 0 \pmod 4 \\ F_d[S(P_n)] &= \frac{n+3}{2} && \text{if } n \equiv 1, 3 \pmod 4 \\ F_d[S(P_n)] &= \frac{n+2}{2} && \text{if } n \equiv 2 \pmod 4. \end{aligned}$$

□

Theorem 7.8. [8, 6] Let $S(C_n)$ denote the splitting graph of the cycle C_n .

Then $\mathcal{Z}(S(C_n)) = 2\mathcal{Z}(C_n) = 4$ and $\gamma(S(C_n)) = \begin{cases} \frac{n}{2} & \text{if } n \equiv 0 \pmod 4 \\ \frac{n+1}{2} & \text{if } n \equiv 1, 3 \pmod 4 \\ \frac{n+2}{2} & \text{if } n \equiv 2 \pmod 4. \end{cases}$

Theorem 7.9. For $n \geq 4$, $F_d[S(C_n)] \leq \begin{cases} \frac{n+4}{2} & \text{if } n \equiv 0 \pmod 4 \\ \frac{n+5}{2} & \text{if } n \equiv 1, 3 \pmod 4 \\ \frac{n+6}{2} & \text{if } n \equiv 2 \pmod 4. \end{cases}$

Proof. For $n \geq 4$, let v_1, v_2, \dots, v_n be the vertices of the graph C_n and u_1, u_2, \dots, u_n be the vertices corresponding to v_1, v_2, \dots, v_n which are added to obtain $S(C_n)$. We know that $\{v_1, v_2, u_2, u_3\}$ forms a zero forcing set. Now depending upon the number of vertices of C_n we consider the following cases and following subsets of the vertex set of $S(C_n)$.

Case 1: Assume $n \equiv 0, 2, 3 \pmod 4$, $D_f = \{u_2, u_3, v_{4k+1}, v_{4k+2}\}$, where $0 \leq k < \lceil \frac{n}{4} \rceil$

Case 2: Assume $n \equiv 1 \pmod 4$, $D_f = \{u_2, u_3, v_{4k+1}, v_{4k+2}, v_n\}$, where $0 \leq k < \frac{n-1}{4}$.

In both cases D_f forms a dom-forcing set. Hence

$$F_d[S(C_n)] \leq \begin{cases} \frac{n+4}{2} & \text{if } n \equiv 0 \pmod 4 \\ \frac{n+5}{2} & \text{if } n \equiv 1, 3 \pmod 4 \\ \frac{n+6}{2} & \text{if } n \equiv 2 \pmod 4. \end{cases}$$

□

Theorem 7.10. [6] Let $S(K_{1,n})$ denote the splitting graph of a Star Graph $K_{1,n}$. Then, for $n \geq 2$, $\gamma[S(K_{1,n})] = 2$ and $\mathcal{Z}[S(K_{1,n})] = 2n - 2$.

Theorem 7.11. Let $S(K_{1,n})$ denote the splitting graph of a Star Graph $K_{1,n}$. Then, for $n \geq 2$, $F_d[S(K_{1,n})] = 2n - 1$.

Proof. For $n \geq 2$, let $u_1, v_1, v_2, \dots, v_n$ be the vertices of the star graph $K_{1,n}$ with $\deg(u_1) = n$ and $u'_1, v'_1, v'_2, \dots, v'_n$ be the vertices corresponding to $u_1, v_1, v_2, \dots, v_n$ which are added to obtain $S(K_{1,n})$. From the above theorem, $\mathcal{Z}[S(K_{1,n})] =$

$2n - 2$ and $B = \{v_2, \dots, v_n, v'_2, \dots, v'_n\}$ forms a zero forcing set which is minimum and any minimum zero forcing set does not contain u_1 . B is not a dom-forcing set. So adding u_1 to B , we get a dom-forcing set which is minimum. Hence $F_d[S(K_{1,n})] = 2n - 1$. \square

Theorem 7.12. [6] Let $S(L_n)$ denote the splitting graph of ladder graph L_n . Then for $n \geq 2$, $\mathcal{Z}[S(L_n)] = 4$.

Theorem 7.13. Let $S(L_n)$ denote the splitting graph of ladder graph L_n . Then, $\gamma[S(L_n)] = 2\lceil \frac{n}{3} \rceil$.

Proof. Let $\{u_1, u_2, \dots, u_n, v_1, v_2, \dots, v_n\}$ be the vertices of the ladder graph L_n and let $\{u'_1, u'_2, \dots, u'_n, v'_1, v'_2, \dots, v'_n\}$ be the vertices corresponding to $\{u_1, u_2, \dots, u_n, v_1, v_2, \dots, v_n\}$ which are added to obtain $S(L_n)$. At least one vertex from $\{u'_1, u_2, v_1\}$, $\{v'_1, v_2, u_1\}$, $\{u'_n, u_{n-1}, v_n\}$, and $\{v'_n, v_{n-1}, u_n\}$ belonging to any dominating set, since $N(u'_1) = \{u_2, v_1\}$, $N(v'_1) = \{v_2, u_1\}$, $N(u'_n) = \{u_{n-1}, v_n\}$, and $N(v'_n) = \{v_{n-1}, u_n\}$. For $0 < k < \lceil \frac{n}{3} \rceil$ at least one vertex from $\{u_{3k}, u_{3k+2}\}$ and $\{v_{3k}, v_{3k+2}\}$ belong to any dominating set, since

$$\begin{aligned} N(u_{3k+1}) &= \{u_{3k}, u_{3k+2}, v_{3k+1}, u'_{3k}, u'_{3k+2}, v'_{3k+1}\}, \\ N(v_{3k+1}) &= \{v_{3k}, v_{3k+2}, u_{3k+1}, v'_{3k}, v'_{3k+2}, u'_{3k+1}\}, \\ N(u'_{3k+1}) &= \{u_{3k}, u_{3k+2}, v_{3k+1}\}, \\ N(v'_{3k+1}) &= \{v_{3k}, v_{3k+2}, u_{3k+1}\}. \end{aligned}$$

Thus any dominating set contains at least $2\lceil \frac{n}{3} \rceil$ number of vertices. For $S(L_1)$, the set $\{u_1, v_2\}$ be a minimum dominating set. For $n \geq 2$, depending upon the number of vertices of L_n , we consider the following subset.

For $n \equiv 0, 2 \pmod{3}$, $S = \{u_{3k+2}, v_{3k+2}\}$, where $0 \leq k < \lceil \frac{n}{3} \rceil$ and for $n \equiv 1 \pmod{3}$, $S = \{u_{3k+2}, v_{3k+2}, u_n, v_n\}$, where $0 \leq k < \lceil \frac{n-1}{3} \rceil$. Now the set S forms a dominating set. So $\gamma[S(L_n)] = 2\lceil \frac{n}{3} \rceil$. \square

Theorem 7.14. For $n \geq 2$,

$$2\lceil \frac{n}{3} \rceil \leq F_d[S(L_n)] \leq 2 + 2\lceil \frac{n}{3} \rceil.$$

Proof. Let $\{u_1, u_2, \dots, u_n, v_1, v_2, \dots, v_n\}$ be the vertices of the ladder graph L_n , and let $\{u'_1, u'_2, \dots, u'_n, v'_1, v'_2, \dots, v'_n\}$ be the vertices corresponding to $\{u_1, u_2, \dots, u_n, v_1, v_2, \dots, v_n\}$ which are added to obtain $S(L_n)$. For $S(L_1)$, $\{u_1, v_2\}$ be a minimum dom-forcing set. For $n \geq 2$, depending upon the number of vertices of L_n , we consider the following cases and following subsets of the vertex set of $S(L_n)$.

Case 1: For $n \equiv 0, 2 \pmod{3}$, $D_f = \{u'_1, v'_1, u_{3k+2}, v_{3k+2}\}$, where $0 \leq k < \lceil \frac{n}{3} \rceil$ and

Case 2: For $n \equiv 1 \pmod{3}$, $D_f = \{u'_1, v'_1, u_{3k+2}, v_{3k+2}, u_n, v_n\}$, where $0 \leq k < \lceil \frac{n-1}{3} \rceil$.

Now D_f forms a dom-forcing set. Therefore, $F_d[S(L_n)] \leq 2 + 2\lceil \frac{n}{3} \rceil$. Domination number of $S(L_n)$ is $2\lceil \frac{n}{3} \rceil$. Hence

$$2\lceil \frac{n}{3} \rceil \leq F_d[S(L_n)] \leq 2 + 2\lceil \frac{n}{3} \rceil.$$

\square

8. CONCLUSION AND OPEN PROBLEMS

In the paper, we address the problem of determining the dom-forcing number of graphs. In Section 2, we found precise values of the dom-forcing number for several renowned graphs. In Section 3, we determined the dom-forcing number of some graphs where $F_d(G) = Z(G)$. In Section 4, we have found the dom-forcing number of some graphs where $F_d(G) = \gamma(G)$. In section 5, we provide some inequalities containing the dom-forcing number of spitting graphs of some graphs.

There are few questions that remains open, for example see the following.

- (1) Characterize the graph G for which $F_d(G) = Z(G)$.
- (2) Characterize the graph G for which $F_d(G) = \gamma(G)$.
- (3) Find the exact value of the dom-forcing number of splitting graphs of graphs like paths, cycles, ladder graphs etc.
- (4) While we have determined $F_d(G)$ for certain well-known graphs, a comprehensive characterization for a wider variety of graph classes remains an open challenge. Extending these results to other families of graphs, such as bipartite graphs, or random graphs, could yield valuable insights.
- (5) Developing efficient algorithms to compute the dom-forcing number for arbitrary graphs is an important practical problem. Given the combinatorial complexity of both dominating sets and zero forcing sets, creating polynomial-time algorithms or approximation schemes would be highly beneficial.
- (6) Exploring the relationships between $F_d(G)$ and other graph parameters, such as, chromatic number, independence number, and spectral properties, could uncover deeper connections and lead to a more unified theory of graph invariants.

REFERENCES

- [1] AIM Special Work Group. Zero forcing sets and the minimum rank of graphs. *Linear Algebra and its Applications*, 428 (7): 1628 - 1648, 2008.
- [2] George Kour and Raid Saabne. Real-time segmentation of on-line handwritten arabic script. In *Frontiers in Handwriting Recognition (ICFHR), 2014 14th International Conference on*, pages 417–422. IEEE, 2014.
- [3] George Kour and Raid Saabne. Fast classification of handwritten on-line arabic characters. In *Soft Computing and Pattern Recognition (SoCPaR), 2014 6th International Conference of*, pages 312–318. IEEE, 2014.
- [4] Guy Hadash, Einat Kermany, Boaz Carmeli, Ofer Lavi, George Kour, and Alon Jacovi. Estimate and replace: A novel approach to integrating deep neural networks with existing applications. *arXiv preprint arXiv:1804.09028*, 2018.
- [5] Allan Frendrup, Michael A. Henning, Bert Randerath and Preben Dahl Vestergaard, *An upper bound on the domination number of a graph with minimum degree 2*, Science Direct, *Discrete Mathematics* 309 (2009), 639-646
- [6] Baby Chacko, Charles Dominic, and K. P. Premodkumar, *On the zero forcing number of graphs and their splitting graphs*, *Algebra and Discrete Mathematics* 28 (2019), 29-43
- [7] Linda Eroh, Cong X. Kang, and Eunjeong Yi, *On zero forcing number of graphs and their complements*, *Discrete Mathematics, Algorithms and Applications*, Vol. 07, No. 01,(2015)
- [8] Samir K. Vaidya1 and Nirang J. Kothari, *Domination Integrity of Splitting Graph of Path and Cycle*,Hindawi Publishing Corporation 2013 (2013)

- [9] Hein van der Holst et al., *Zero Forcing Sets and the Minimum Rank of Graphs*, *Linear Algebra and its Applications*, 428 (2008),1628-1648.
- [10] T. W. Haynes, S. T. Hedetniemi and P. J. Slater, *Fundamentals of domination in Graphs*, New York: Dekker, (1998).
- [11] Dr. A. Sugumaran, E. Jayachandran, *Domination number of some graphs*, IJSDR 3 (2018)
- [12] A N Hayyu, Dafik, I M Tirta, R Adawiyah, R M Prihandini *Resolving domination number of helm graph and it's operation* Journal of Physics: Conference series 1465(2020)
- [13] Darren Daniel Row *Zero forcing number: Results for computation and comparison with other graph parameters*, Iowa State University (2011)
- [14] K. Owens. *Properties of the zero forcing number*. Brigham Young University. Dept. of Mathematics, (2009).
- [15] Fatemeh Alinaghipour Taklimi. *Zero forcing sets for graphs*. University of Regina. Dept. of Mathematics, (2013)
- [16] Charlse Dominic. *Zero forcing number of degree splitting graphs and compete degree splitting graphs*. Acta Univ. Sapientiae, Mathematica 11 (2019)
- [17] J Anitha *Zero forcing in snake graph*, International Journal of Recent Technology and Engineering (IJRTE), Volume 7 (2019)
- [18] Erin O'Connor Gray *Dominion on Ladders*, Department of Mathematics Computer science and engineering technology, Elisabeth city state University (2023).
- [19] DeAlba et al *Universally Optimal Matrices and Field Independence of the Minimum Rank of a Graph*, Electronic Journal of Linear Algebra, Volume 18 (2009).
- [20] Randy Davila, Michael A. Henning, Colton Magnant and Ryan Pepper, *Bounds on the Connected Forcing Number of a Graph*, Graph and Combinatorics, Volume 34 (2018).
- [21] S. Teresa Arockiamary *Total Edge irregularity strength of diamond snake and dove* International Journal of Pure and Applied Mathematics, Volume 109 (2016).
- [22] Peter Collier *Zero Forcing Processes on Proper Interval Graphs and Twisted Hypercubes* , Dalhousie University Halifax, Nova Scotia (2023)
- [23] T. Peters, *Positive semidefinite maximum nullity and zero forcing number*, Electron.J. Linear Algebra 23 (2012)
- [24] Leslie Hogben, My Huynh, Nicole Kingsley, Sarah Meyer, Shanise Walker, Michael Young, *Propagation time for zero forcing on a graph*, Arxiv (2014)
- [25] E. Sampathkumar and H.B. Walikaer, *On the splitting graph of a graph*, Journal of Karnataka University Science 25, (1981)