

Design, Casting and Performance Evaluation of Automotive Piston using Hybrid AA6061/SiC/Carbonized Coconut Shell Nanocomposite

Abstract

The application of conventional monolithic materials in automotive and aerospace components has resulted in huge fuel consumption, high operational cost and frequent components failure. Engineered materials have therefore gained popularity in recent decades owing to their excellent properties which enhance high fuel economy, reliability and low operational cost. This study designed and fabricated an automobile piston using synthesized hybrid AA6061/silicon carbide/carbonized coconut shell nanocomposite. The hybrid nanocomposite consisted of AA6061 alloy reinforced with nanoparticles of carbonized coconut shell (CCS) and silicon carbide (SiC), combined in the ratio 1:1, and average particle sizes of 42.3nm and 50.01nm for SiC and CCS respectively. The composite samples (consisting of 3, 6, 9, 12 and 15% wt. each of the reinforcement materials), were produced by the stir casting method, and characterized for physical, mechanical, tribological and thermal properties. The composite with optimal properties (AA6061/SiC/CCS containing 9% wt. each of SiC and CCS) was used for the casting of the car piston. The fabricated AA6061/SiC/CCS nanocomposite piston was tested with Model 12 valve engine and the results obtained were compared with those of conventional piston and other investigators. The average fuel consumption of the engine using the fabricated piston, was found to be 0.00701 litres/kWh, resulting in a 16.83% savings in fuel consumption when compared with the conventional piston. Also, the density of the designed piston material reduced significantly by 8.5% of the density of the base alloy, resulting in efficient fuel saving, with ultimate tensile strength ranging from 176 – 249 MPa.

Keywords: Piston, composite, nanoparticles, AA6061 alloy, stir casting, reinforcements, automobile

1. Introduction

“The automobile industry is one of the major beneficiaries of engineered materials in recent time as these materials enhance high fuel consumption efficiency and strength to weight ratio. Because of their excellent physical, mechanical, thermal and tribological properties, aluminium matrix composites are now replacing monolithic materials in automobile and aerospace applications. Some of the applications of aluminium matrix composites are in production of piston, engine block bottom plate, etc. A piston is a movable element of an internal combustion (I.C.) engine usually fitted into the cylinder to receive and transmit power. In an engine, its purpose is to transfer force from expanding gas in the cylinder to the crank shaft via a connecting rod. The piston's primary responsibility is to take thermal energy created by the ignition of fuel and air and transform it into linear motion. The piston's linear motion acts on the crankshaft journal and becomes rotary motion”[1]. “To function efficiently, the piston is also expected to dissipate very huge amount of heat from the combustion chamber to the cylinder walls. The pistons are usually subjected to both thermal and mechanical loading during engine operation. Mechanical loading is caused by the gas pressure in the cylinder and the reaction from the gudgeon pin and the cylinder wall. Thermal loading is caused by the temperature and heat transfer condition in the cylinder and at other boundaries to the piston. It is therefore necessary to understand the loading because this provides the basis for design, the reason for oil cooling and

the cause of structural failure of a piston. In addition to the piston design, material is a major element in the piston manufacturing” [2].

The structure of the piston may be categorized into two sections, which are the top section and the lower section. The top section is called the head or crown, while the lower section is called the skirt. The pistons of internal combustion engines are mostly of trunk type as given in Figure 1.

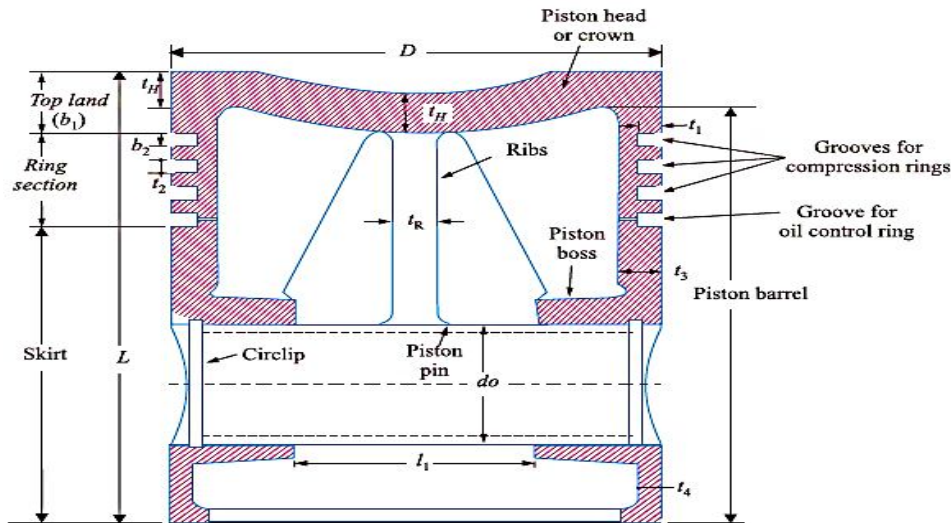

Figure 1: Section of Piston for I.C. engines [2]

The main parts of the trunk type pistons are the head, piston rings, skirt and piston pin. The piston head or crown is the top surface where the gas explosive pressure is exerted when the piston moved up and down in the combustion chamber. Therefore, it is usually thick to resist the high gas pressure and to provide a smooth heat flow from the crown to the combustion rings. The shape of the piston crown depends on the design of the combustion chamber. There are various shapes such as concave, flat, cup, dome, hump and contour to promote turbulence in combustion or to control the combustion process (Figure 2). The piston rings are used to seal the cylinder in order to prevent leakage of the gas past the piston. The skirt serves as bearing for the side thrust of the connecting rod on the cylinder walls while the piston pin also known as wrist pin or gudgeon pin is used to link the piston with the connecting rod.

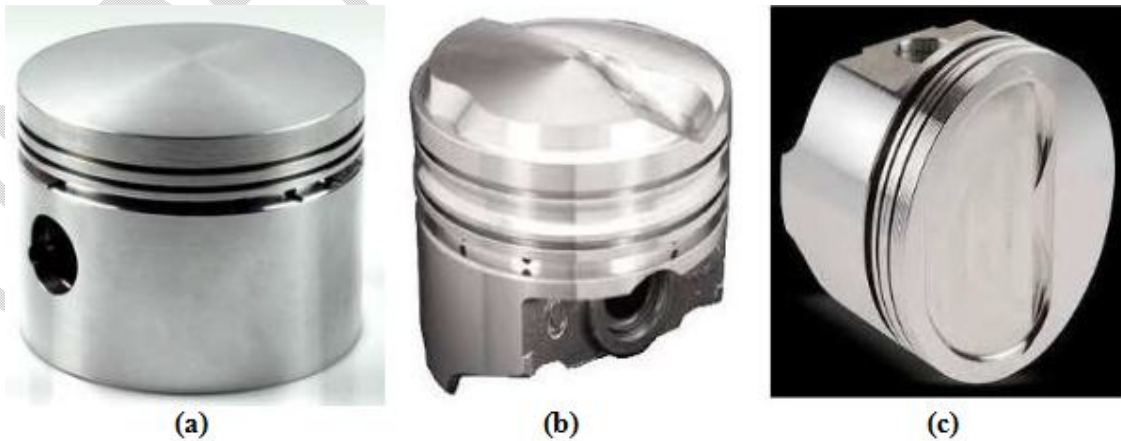

Figure 2: Piston heads (a) Flat head (b) Concave head (b) Convex Piston [2]

Several investigations in recent times have been focused on the use of agro-wastes for composites production. This in turn, helps to reduce waste disposal and result in cost effective materials production. Some of the agro-reinforcement materials reported in literature include periwinkle shell ash, beans pod ash, egg shell ash, sugar cane bagasse, palm oil fuel ash, palm kernel ash, rice waste ash, coconut shell ash, etc. [3,4]. The use of coconut shell particles in both carbonized and uncarbonized form has also gained popularity among researchers. Donald *et al.* [5] reported the “development and characterization of aluminum matrix composites reinforced with carbonized coconut shell and silicon carbide particle for automobile piston application in which the composite samples were prepared using powder metallurgy technique with 0, 2, 4, 6, 8, and 10 wt % of reinforcement. Mechanical and thermal properties were investigated. For green compacts, a range of 66.17-107Hv, was obtained for hardness, while for sintered compacts the values obtained are 72.57 – 105.47Hv, 172.25 – 207.61MN/m² and $2.2136 \times 10^{-5} \text{ K}^{-1}$ – $2.5804 \times 10^{-5} \text{ K}^{-1}$ for hardness, tensile strength and coefficient of thermal expansion respectively. Microstructural examination of developed composites materials reveals that the reinforcement particles were uniformly distributed in the base matrix and that bonding took place between the base matrix and reinforcements after sintering”.

Vetrivelet *al.* [1] presented the “modelling and static structural analysis of an engine piston using pure aluminium-12.5% silicon based composite material reinforced with 3% silicon carbide and 15% cenosphere particulates subjected to consider gas pressure at 18 MPa. The piston was modelled in CATIA along with HYPER MESH and ANSYS. The performance of the piston was compared with those made from LM26 and A4032. The results clearly showed that the piston with aluminium MMC’s had better results than the former materials. When compared to the conventional material the new material found to have less weight and greater strength”. Sivabalan *et al.* [6] “designed and analyzed a ceramic matrix composites piston to check whether the induced stresses were within the permissible limit. The method includes modelling, meshing, and analyzing the model, created using the pro/E package, The model was translated to the finite element analysis (FEA) package through the IGES translator. The translated model was parametrically meshed, with boundary and loading conditions applied. It then was analyzed using static analysis module. From the results, it was found that the maximum deflection of the piston for composite materials was very low compared to that of the existing material”. The tensile strength for CMC and MMC pistons were respectively 216.798 MPa and 168.056 MPa, with deflections 0.01634 mm and 0.008149 mm for CMC and MMC pistons respectively.

2. Materials and Method

The materials used in this study were aluminium alloy 6061 (matrix material), silicon carbide and carbonized coconut shell (both used as the reinforcements). Table 1 shows the chemical composition of AA6061. Samples of the hybrid composites consisting of carbonized coconut shell particles CCS and silicon carbides SiC were fabricated using stir casting method [7,8]. In order to produce coconut shell nanoparticles, mature coconut shells were first broken into smaller pieces, washed with water to remove dirt and then sun dried for two days to reduce its moisture content. It was then carbonized by heating it in a muffle furnace to a temperature of 700°C in the absence of air to form coconut shell char. This was followed by ball milling for particle sizing using a set of sieves. The milling was carried out in two stages, namely: pre-classification milling for producing CCS micro-particles and post classification milling for producing CCS nanoparticles. Hence, further reduction in particle size was achieved by milling particles retained on the sieve below 63

um for a total duration of 60 hours and classified using x-ray diffractometer (XRD). The sample was taken out after every 10 hours of milling and characterized for its crystallite size. Nanoparticles of average size of 50.01 nm for CCSp at 60 hours of milling were produced. Also, silicon carbide (SiC) powder of initial particle size of 38 μm was reduced to nano size using a high-energy planetary ball mill in a stainless steel chamber having tungsten carbide and zirconia balls of 10 mm diameter and 3 mm diameter ball sizes respectively for total milling duration of 50 hours. The rotation speed of the planet carrier was 200 rpm. The ball mill was loaded with ball to powder weight ratio of 10:1. Toluene was used as the medium with an anionic surface-active agent to avoid agglomeration. The milled sample powder was taken out at a regular interval of every 10 hours of milling and dried with mechanical drier, and characterized for particle size using scanning electron microscope. The reinforcements with average particle sizes of 42.3 nm and 50.01 nm for SiC and CCS respectively were used for producing different samples of the composite containing 3, 6, 9, 12 and 15 wt% each of CCS and SiC. The equipment and method of fabrication of composite samples are contained in the reports by Nwigbo[7] and Nwigbo and Umoru[8]. The fabricated composite samples were characterized for density, strength, hardness and thermal conductivity in accordance with standard test procedures [7,8]. The procedure adopted in casting the piston involves production of wooden pattern, preparation of sand core, followed by mold preparation, pouring and finishing. Figure 3 gives pictorial views of some of the processes involved in the casting of the piston.

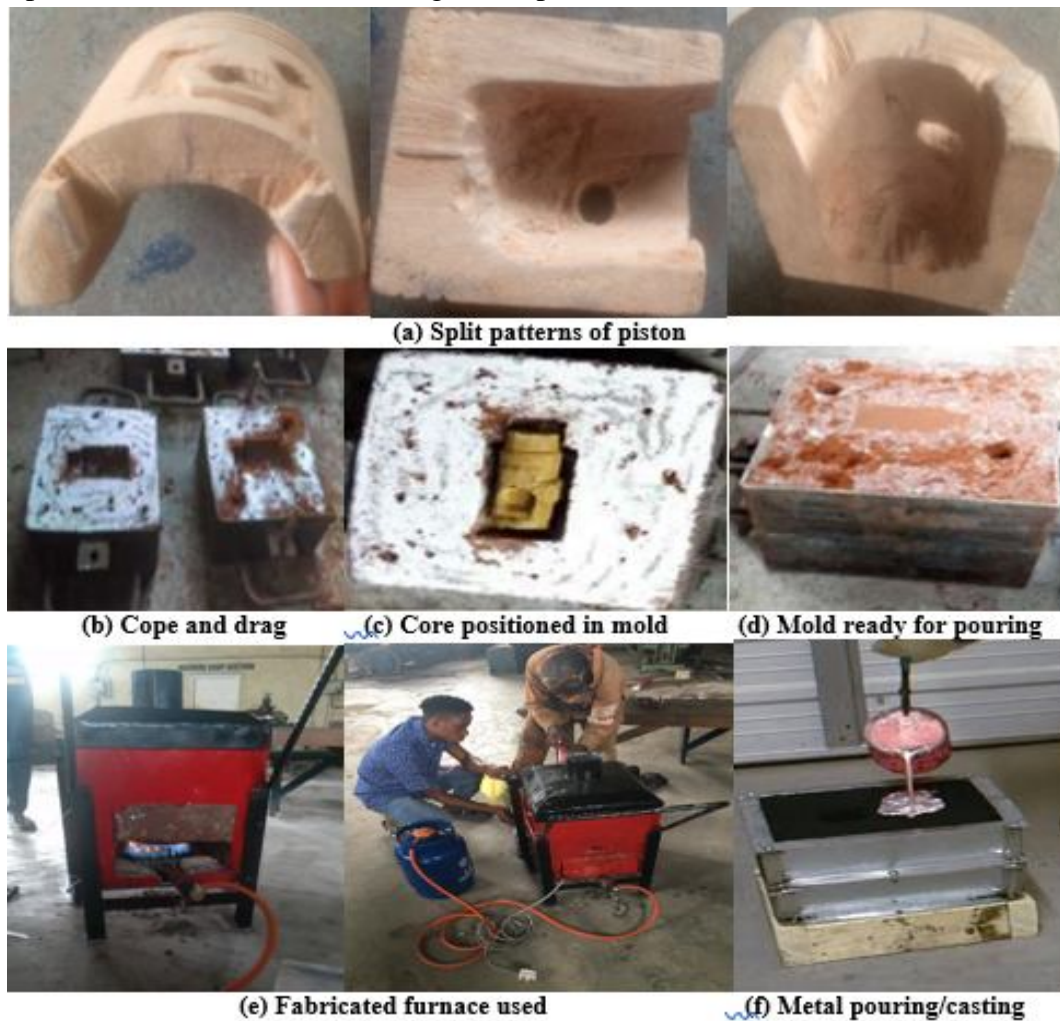

Figure 3: Casting processes of the piston

Table 1: Composition of AA6061

Element	Si	Fe	Cu	Mn	Mg	Ni	Zn	Ti	Cr	Al
Weight %	0.514	0.230	0.161	0.071	0.960	0.010	0.015	0.031	0.103	Bal.

2.1 Design of Piston

In designing a piston for I.C. engine, the following points should be taken into consideration [2]:

- (i) It should have enormous strength to withstand the high gas pressure and inertia forces
- (ii) It should have minimum mass to minimize the inertia forces
- (iii) It should form an effective gas and oil sealing of the cylinder
- (iv) It should provide sufficient bearing area to prevent undue wear
- (v) It should disperse the heat of combustion quickly to the cylinder walls
- (vi) It should have high speed reciprocation without noise
- (vii) It should be of sufficient rigid construction to withstand thermal and mechanical distortion
- (viii) It should have sufficient support for the piston pin

2.2 Piston Head

The thickness of the piston head (t_H), on the basis of the strength to be withstood by the straining action due to pressure of explosion inside the engine cylinder is estimated according to Grashoff's formula is given by

$$t_H = \sqrt{\frac{3pD^2}{16\sigma_t}} \text{ (in mm)} \quad (1)$$

where, p is the maximum gas pressure or explosion pressure in MPa, D is the cylinder bore or outside diameter of the piston in mm, and σ_t is the permissible bending (tensile) stress for the material of the piston in MPa.

On the basis of heat transfer, the thickness of the piston head should be such that the heat absorbed by the piston due combustion of fuel is quickly transferred to the cylinder walls. Treating the piston head as a flat circular plate, its thickness is given by Equation (2) [2].

$$t_H = \frac{H}{12.56K(T_C - T_E)} \text{ (in mm)} \quad (2)$$

where, H is the heat flowing through the piston head in kJ/s or kW, k is the heat conductivity factor in W/m/°C (its value is 174.75 W/m/°C for aluminium alloys), T_C is the temperature at the centre of the piston head in °C, and T_E is the temperature at the edges of the piston head in °C. The temperature difference ($T_C - T_E$) and is taken as 75°C for aluminium alloy.

The heat flowing through the piston head (H) may be determined by the following expression, i.e.,

$$H = C \times (HCV) \times m \times (B.P.) \text{ (in kW)} \quad (3)$$

where, C is a constant representing that portion of the heat supplied to the engine which is absorbed by the piston. Its value is usually taken as 0.05. HCV is the higher calorific value of the fuel in kJ/kg (which may be taken as 47×10^3 kJ/kg for petrol), m is the mass of the fuel used in kg per brake power per second, and $B.P.$ is the brake power of the engine per cylinder.

2.3 Piston Barrel

It is a cylindrical portion of the piston. The maximum thickness (t_3) of the piston barrel may be obtained from the following empirical relation[2];

$$t_3 = 0.03D + b + 4.5 \text{ (mm)} \quad (4)$$

where, b is the radial depth of piston ring groove which is taken as 0.4 mm larger than the radial thickness of the piston ring (t_1).

$$b = t_1 + 0.4 \text{ (mm)} \quad (5)$$

Thus, Equation (4) may be written as,

$$t_3 = 0.03D + t_1 + 4.9 \text{ (mm)} \quad (6)$$

The piston wall thickness (t_4) towards the open end is decreased and should be taken as $0.25t_3$ to $0.35t_3$. In this work t_4 was taken as $0.3t_3$

2.4 Thickness of the Sealing Part of the Piston

The thickness (s) of the sealing part was estimated according to Prasad *et al.* [9], given as:

$$S = 0.05 \times D \quad (7)$$

Therefore $S = 0.05 \times 72 = 3.6 \text{ mm}$

The engine used for this work is a 4 cylinders four stroke, model 12V petrol engine. The engine specifications are given in Table 2.

Table 2: Engine Specifications

PARAMETERS	SYMBOLS	VALUES
Engine Type		Four stroke, petrol engine
Number of cylinders		4 cylinders
Bore Diameter	D	72.0mm
Piston Stroke	↓	77.4mm
Displacement volume	X	1295 cc
Compression ratio	CR	9.5/1
Maximum power	P	74 kW
Maximum torque	T	117N-m
Number of revolutions/cycle	N	800 rpm

2.5 Geometric Model of Piston

The geometric piston model of Vetrivelet *al.*[1] was adopted using CATIA and the piston designed according to the specification of a 4 cylinders four stroke, model 12V petrol engine (Table 2) and design data of Equations (1 – 7) as depicted in Figure 4.

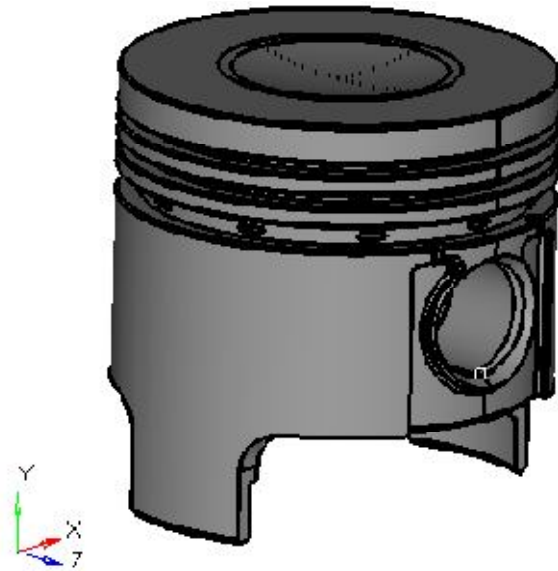

Figure 4: Geometric model of piston [1]

2.6 Production of Car Piston

The composite car piston was cast and machined using specifications of Model 12 valve engine given in Table 2 and the design data. The pattern was constructed with wood, showing all the necessary cavities as indicated in the original piston. The mould was designed in two parts (cope and drag) with a gating system which aid the flow of the molten metal into the intrinsic cavities of the mould. Parting dust was used as the mould release agent and it was sprayed directly on the cavities of the mould. Of the aluminium alloy, 700g was weighed and melted and 9 wt% each of silicon carbide and carbonized coconut shell nanoparticles was added to the molten aluminium alloy and stirred vigorously for 2 to 3 minutes to attain a homogenous mixture. The homogenous mixture (at 700°C) was then carefully poured into the mould cavity (at 80°C) and allowed to solidify. After 24 hours, the casting was carefully removed from the mould with the help of chisel. The cast piston was then machined and finished to the required dimensions.

2.7 Performance Evaluation of the Fabricated Nanocomposite Piston

The performance evaluation of the designed and fabricated AA6061/SiC/CCS composite piston was carried out by comparing its experimental test results with those of conventional piston and other investigators. To this end, a Model 12 valve engine shown in Figure 5, was used in carrying out the performance test following the method adopted by Nwigbo[7] and Abba-Aji[10] in the Automotive workshop at Kenule Beeson Saro-Wiwa Polytechnic, Bori. The engine was assembled with conventional and the fabricated AA6061/SiC/CCS nanocomposite pistons serviced and then test run to determine its performance and effectiveness. Fuel of 100ml (0.1 litres) was discharged into the fuel chamber using a calibrated glass cylinder then the engine was allowed to run until the fuel in the chamber was consumed. This process was repeated two more times with 200ml (0.2 litres) and 300ml (0.3 litres) of fuel respectively. The duration of fuel consumption in each case was recorded. The fuel consumption per kilowatt hour of the fabricated AA6061/SiC/CCS nanocomposite piston and the conventional standard piston was estimated using Equation (8) [10].

$$\text{Fuel consumption /KWh} = \frac{\text{Volume of fuel in litres}}{\text{Time taken to consume} \times \text{Power [kW]}} \quad (8)$$



Figure 5: Testing pistons on Toyota Model 12 valve engine, in Automotive Workshop, Kenule Beeson Saro-Wiwa Polytechnic, Bori, 2021)

3. Results and Discussion

3.1 Performance Evaluation of the Fabricated Piston

Figure 6 shows a cast composite piston produced, using the optimum composite after a comparative analysis of the properties of the various composite samples. The results of the piston design, performance test and computational analysis are given in Table 4 and Figures 7(A-B). The average fuel consumption of the engine was 0.00701 litres/kWh, 0.00642 litres/kWh and 0.00583 litres/kWh with conventional piston, that of Abba-Aji[10] and the present work respectively. The performance tests showed that the engine fuel consumption when using the developed hybrid AA6061/SiC/CCS piston was lower than that of regular pistons, resulting in a 16.83% savings in fuel consumption when compared with the conventional piston, leading to lower running costs. Similar trend was observed with that of Abba-Aji[10] who reported an 8.41% savings in fuel consumption with the use of AMC piston on the same car model in a similar test. Hence, the replacement of the conventional piston material with hybrid aluminium nanocomposite gave improved strength, minimize weight, reduce induced stresses in the structure and enhance fuel consumption economy.



Figure 6: Cast nanocomposite pistons

Table 3: Piston design output

S/N	Parameters	Design Output [mm]
1	Piston head thickness	4.00
2	Piston ring radial thickness	2.45
3	Piston radial depth	3.00
4	Piston barrel thickness	9.51
5	Piston wall thickness	3.00
6	Thickness of sealing part	3.60

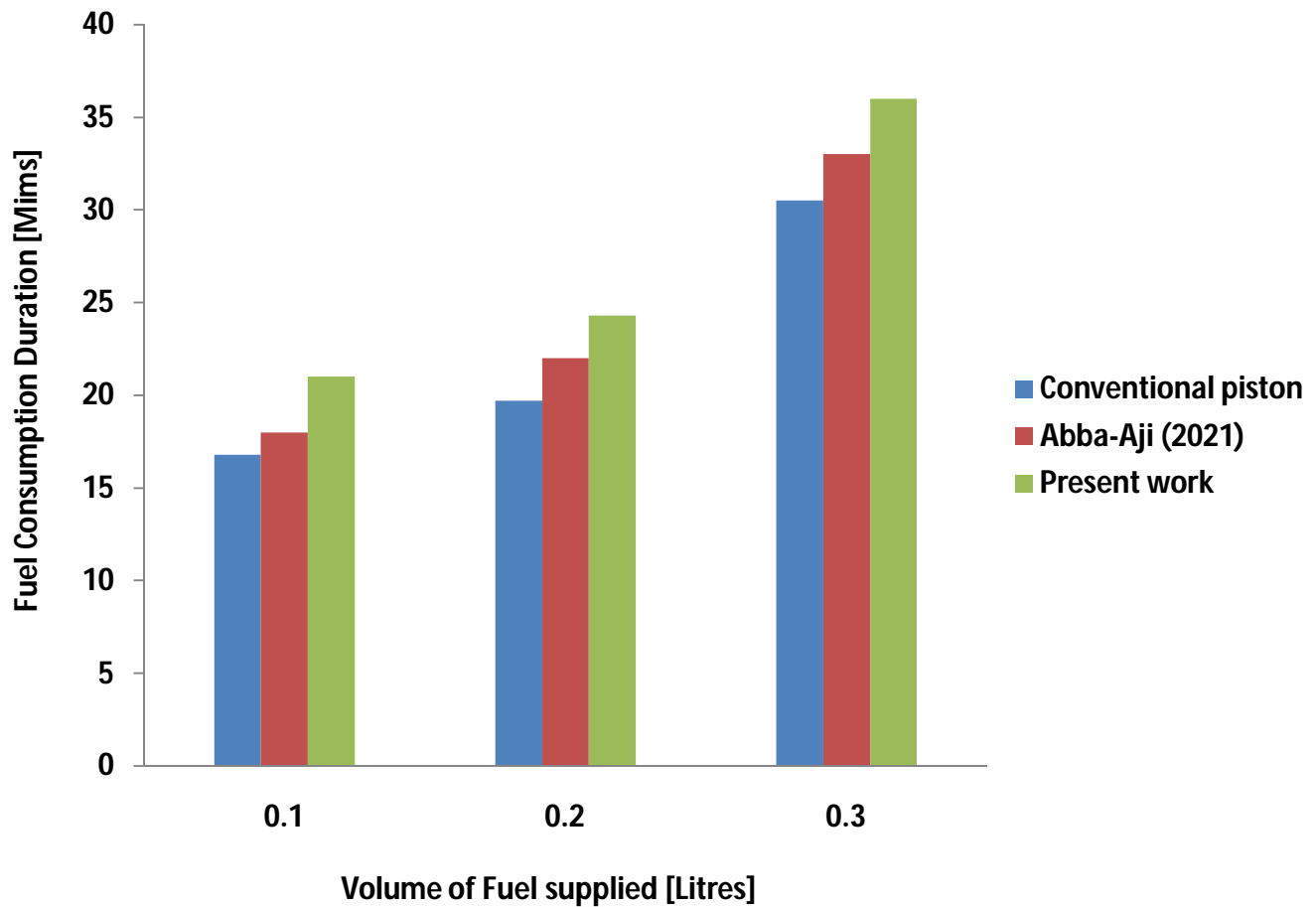

Figure 7a: Engine fuel consumption duration

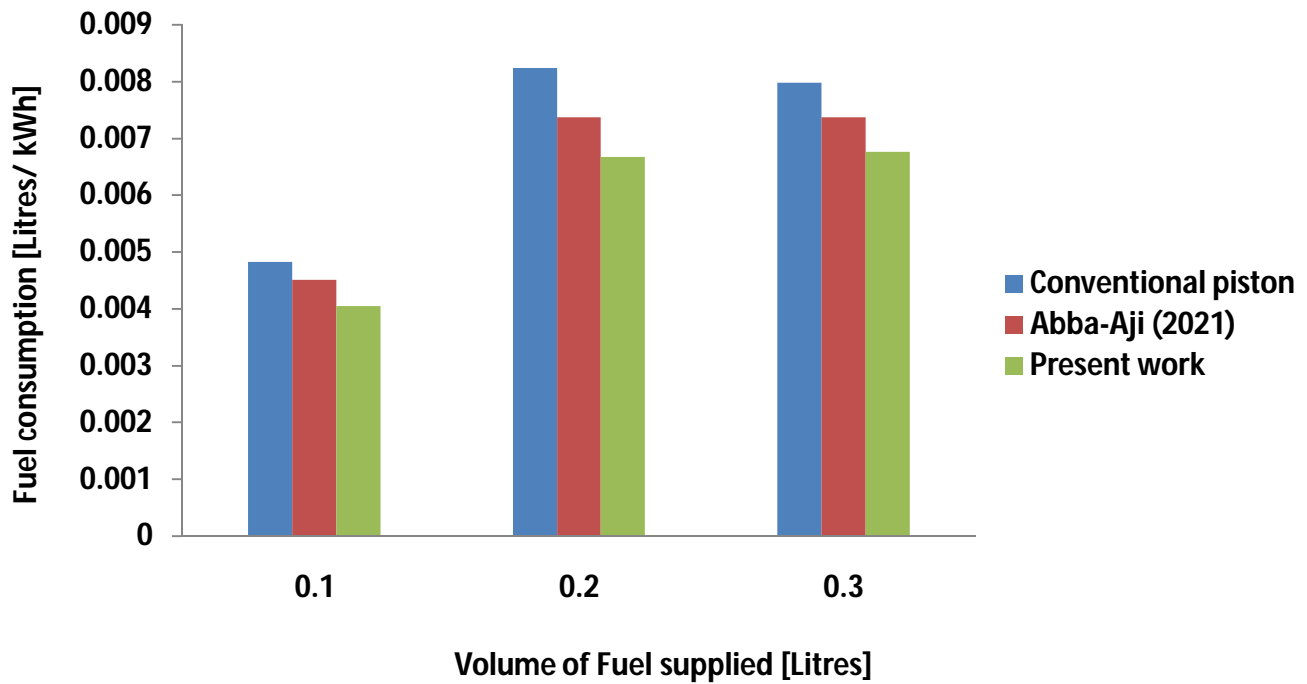

Figure 7b: Engine fuel consumption duration

3.2 Validation of Results

The properties of aluminium alloy 6061 reinforced with nanoparticles of carbonized coconut shell and silicon carbide, along with generic values, results obtained by Abba-Aji[10], Donald *et al.*[5] and Sivaramakrishnan *et al.*[11] are presented in Table 4. Comparing the obtained properties of prepared composite material with that of the generic material and those of other authors for piston application shows that the obtained values are within acceptable range of generic properties of piston materials.

Table 4: Comparison of obtained with generic piston material properties and previous research

S/N	Authors	Ultimate Tensile Strength [MPa]	Yield Strength [MPa]	Hardness [Hv]	Density [g/cm ³]	Thermal Conductivity W/mk
1	Generic	180 – 230	140 – 200	95 – 135	2 – 3	205 – 215
2	Base alloy	162.6	135.5	78.75	2.72	151 – 202
3	Abba-Aji (2021)	200.77	196.77	53 – 60.15	2.66	172
4	Donald <i>et al.</i> , (2018)	172.25 – 207	182.8	64.97 – 115	2.71	221 – 225
5	Sivaramakrishna <i>et al.</i> , (2019)	199	196	66 – 105	2.78	120
6	Present work	176 – 249	175 – 231	81 – 95	2.49	167 – 184.2

4. Conclusion

The hybrid AA6061/SiC/CCS nanocomposite was successfully produced by stir casting method, characterized and applied for fabrication of automotive use. The effect of reinforcement weight fraction on the properties of the developed nanocomposite was also investigated. From the analysis of results obtained during this study, the following conclusions were made:

- (i) The stir casting method can be successfully used to fabricate the AA6061/SiC/carbonized coconut shell nanocomposite pistons for automotive application
- (ii) The average fuel consumption of the engine using the fabricated piston, was found to be 0.00701 litres/kWh, resulting in a 16.83% savings in fuel consumption when compared with the conventional piston.
- (iii) The density of the designed piston material reduced significantly by 8.5% of the density of the base alloy, resulting in efficient fuel saving, with ultimate tensile strength ranging from 176 – 249 MPa.
- (iv) The developed nanocomposite could be suitable for automotive and aerospace applications.

DISCLAIMER (ARTIFICIAL INTELLIGENCE)

Author(s) hereby declare that NO generative AI technologies such as Large Language Models (ChatGPT, COPILOT, etc.) and text-to-image generators have been used during the writing or editing of this manuscript.

References

- [1] Vetrivel, M., Sankar, M., Azhaguvelu, R., Sathishkumar, E. S. and Prabu, R. (2023). Design and development analysis of piston by using Al-Si hybrid MMC's reinforced with SiC and cenosphere particulates. *Journal of Emerging Technologies and Innovative Research*, 10 (10), 671 – 685.
- [2] Khurmi, R. S. and Gupta, J. K. (2007). *A Textbook of Machine Design*. S. Chand and Company Limited, New Delhi.
- [3] Senthilkumar, G., Manoharan, S., Balasubramanian, K. and Dhanasakkaravarthi, B. (2016). An experimental investigation of metal matrix composites of aluminium (Lm6), boron carbide and fly ash. *Australian Journal of Basic and Applied Sciences*, 10 (1), 137 – 144.
- [4] Iyasele, E. O. (2018). Comparative analysis on the mechanical properties of a metal matrix composite reinforced with palm kernel/periwinkle shell ash. *Global Scientific Journal*, 6 (8), 1 – 24.
- [5] Donald, A. O., Hassan, M. A., Hamza, S., Garba, E., Dangtim, D. K. and Mamadou, M. (2018). Development and characterization of aluminum matrix composites reinforced with carbonized coconut shell and silicon carbide particle for automobile piston application. *Global Scientific Journals*, 6(8), 390 – 398.
- [6] Sivabalan, S., Sathishkumar, G., Sridhar, R. and Pugazhenthii, R. (2018). Design and analysis of ceramic matrix composites piston. *International Journal of Management, Technology and Engineering*, 8 (7), 4715 – 4724.
- [7] Nwigbo, M. N. (2023). *Synthesis, Characterization and Modelling of Aluminium-6061 Matrix Nanocomposite Reinforced with Silicon Carbide and Carbonized Coconut Shell Particles for Automotive Applications*. PhD Thesis, University of Uyo, Nigeria.
- [8] Nwigbo, M. N. and Umoru, L. E. (2023). Tribological behavior of hybrid AA6061/SiC/carbonized coconut shell nanocomposites. *Journal of Materials Science Research and Reviews*, 6 (3), 248 – 257.

- [] Prasad, N. (2006). *Development and Characterization of Metal Matrix Composite using Red Mud an Industrial Waste for Wear Resistant Application*. PhD Thesis. National Institute of Technology, Rourkela, India, 184p.
- [10] Abba-Aji, M. A. (2021). *Development of Car Piston Material from Aluminium Alloy using Coconut Shell Ash as an Additive*. PhD Thesis, Federal University of Technology, Minna, Nigeria.
- [11] Sivaramakrishnan, K., Jithendra, G. and Ajith, V. K. (2019). Design and analysis of four stroke engine piston. *International Journal of Engineering Science and Computing*, 9(2), 743-746.

UNDER PEER REVIEW