

Development of a Robotic Weed Control System for Greenhouse

Abstract

In this study, a robot prototype that moves on a monorail was designed and developed using analytical and experimental methods. Its purpose was weed elimination between cucumber plants inside the greenhouse plants since there is not much research done for a robotic weed control in a cucumber greenhouse. The plants are cultivated in one row and the distance between two plants is about 40 cm. The distance between two rows is almost 1 meter. The soil type of the cucumber greenhouse was sandy loam soil. The robot benefits from 3 arrays of ultrasonic sensors for weed detection and a PIC18 F4550-E/P microcontroller board for processing. The feedback from the sensors activates a robotic arm which moves inside the rows of the cucumber plants for cutting the weeds using rotating blades. Fifty four experiments were carried out inside a greenhouse to find the best combination of arm motor (AM) speed, blade rotation (BR) speed, and blade design. Three BR speeds of 3500, 2500 and 1500 rpm were assigned. The selection of the BR speeds was based on the previously published results on rotary movers, and two AM speed of 10 and 30 rpm to three blade designs of S-shaped, triangular-shaped, and circular-shaped. These blades were selected due to their availability, low cost, and their performance during the initial test experiments.

Since the study results indicated that as much as the speed of the engine is further, the percentage of cut weeds reduces, therefore, the motor of 10-rpm was selected to move the arm.

Keywords: greenhouse, weed control robot, weeds, Greenhouse

Introduction

The world's point of view about the usage of the resources has changed, and the extensive agriculture is replaced by compact cultivation. Indiscriminate use of chemicals has changed with its reasonable alternatives. The demand for off-season production of fruits and vegetables and other agricultural products require controlled environmental conditions. The greenhouse technology can answer almost all the items mentioned above. In addition, greenhouse technology is a career in which payback occurs very quickly. One of the main reasons to exchange greenhouse cultivation with open-field cultivation is to be able to better control environmental conditions. A

greenhouse generally is a closed, roofed area. It looks like a big room from a distance. A greenhouse can protect crops against factors such as high temperatures, strong winds, heavy rains, devastating storms, pests, and diseases. Other benefits of the greenhouse technology include off-season production, efficient use of equipments, increasing the export capacity, annual production per unit area, and the productivity of resources, and ultimately improving profitability. Greenhouse cultivation is an agricultural technique that has many advantages compared with the open-field cultivation. Tropical conditions for vegetable production throughout the year is ideal, depending on the temperature and light in a good condition for greenhouse cultivation by reducing bottlenecks in the production of high quality fruits and vegetables. Vegetable production in the tropics is one of the main sources of fresh food, minerals, and especially rural

livelihoods.(Vilas and Ajay, 2011).To date, many methods and ways have been proposed to prevent the growth of weeds,including controlling them before cultivating the main plant and after that. In the first method, the soil can be disinfected the soil bed before planting either naturally or chemically. The chemicals are used to prevent the growth of weeds that remain in the soil for a long time and cause poisoning (acidic). In the second method, a dark plastic cover is pulled over the greenhouse and on the ground floor in the summer. This increases the temperature under the plastic significantly which in turn results in the destruction of the weed seeds. This method is expensive, and also a high percentage of weeds maintain their potential to grow.Another method is to remove weeds entangling with the main crop using herbicides. which are usually general type of herbicides due to a variety of weeds including(hardwood, narrow leaves, etc.). However, it must be noted that not only do herbicides pollute the soil but also a small mistake can lead to the loss of the main plant.

This review clearly shows that new methods for removing weeds in the greenhouses such as using weeding robots are necessary. Therefore, in this study, a robot was designed that can move in cucumbers greenhouses where the products are planted in the ground floor. The robot, removes the weeds and solves the problems related to the manual methods. In this study, an attempt has been made to remove weeds through the fastest mechanical method and without the use of chemicals. In addition to being economical for the farmers, this method is very simple to understand and apply.The main application of robots in the commercial sector has been concerned with the substitution of manual human labour by robots or mechanized systems to make the work more time efficient, accurate, uniform and less costly (Sezen, 2003; Hopkins, 2000; Giacomelli and Ting, 1995; Van Henten et.al., 2003; Pilarski, 2002). Producers believe that automation is a viable and sometimes necessary (Giacomelli and Ting 1995) method to ensure maximum profits with minimum costs (Hopkins 2000). They proposed a machine vision system using a charge coupled device camera for the weed detection in a radish farm. The success rate of recognition was 92% for radish and 98% for weeds (Cho et al. 2002). Recent advances in robotics enable the application of mobile robots for greenhouse tasks which can reduce operator's fatigue and workload, improving the efficiency and operational safety. Manipulator robots have been successfully tested, these robots usually being controlled by vision systems (Sandini et al., 1990; Dario et al., 1994; Kondo and Ting, 1998).Some of these alternatives are self-propelled vehicles such as Fumimatic® (IDM S.L, Almería, Spain) and Tizona (Carretillas Amate S.L., Almería, Spain), or autonomous vehicles such as Fitorobot (Universidad de Almería, Cadia S.L., Almería, Spain), designed specifically to move without difficulty over loose soils and in spaces with a large number of obstacles (Sánchez et al 2010). These vehicles rely on (inductive) sensors to follow metal pipes buried in the soil; few projects have addressed the navigation problem of vehicles in greenhouses operating completely autonomously [González et al 2009, Mandow et al 1996, and Subramanian et al 2005]. The main challenge of these systems is that localization approaches needed for feeding the closed-loop controllers would lead to inaccurate measurements after a few steps fail for long trajectories (Borenstein et al 1996). A stereovision system along with an image processing algorithm was used to recognize the weeds and also to estimate their location in the field. Various researchers have conducted research regarding general weed control and elimination in external (outdoor) environments. In addition, these researches have been conducted only for a few specific plants. Most of the research in areas of robotic weed control is conducted before the plant growth or in some cases where the main plant is 20 – 30 cm in height. Thus, this research can only serve as a

useful guide to help us conduct this research regarding robotic weed control and elimination in an indoor environment and where the main plant can grow even up to 10 meters.

The goal of this study is to design and develop machinery to control weeds in greenhouses without using chemical materials. The main objective of this research was to develop and test a robot for weeding in between cucumber plants in a greenhouse with some specific conditions for it to be functional.

Materials and Methods

Study area

Jiroft is in southern part of Iran with latitude/longitude 67,028, 28 North and 73694, 57 East with an altitude of 690 meters above the sea level and average annual rainfall of 87 mm and a mean annual temperature of -2 to +48 ° C. And also because of the fertile soil and sufficient water resources, farmers have the opportunity to cultivate in the cold season (winter) . Because of the temperate weather for about 8 months of the year (from October to April), there is no need for heaters in greenhouses, which leads to low production costs, thereby encouraging landowners to construct greenhouses. Currently there are over two thousand five hundred hectares of greenhouses in the area and surrounding villages. Jiroft is not only one of the greenhouse regions in Iran but also in the Middle East. There are about 5 thousand hectares of small tunnel temporary greenhouses that are gathered outside the growing season and again are constructed at the beginning of the next season.

Methods

Design of main components of the robot weed control:

The general objective of this study was to design, develop, fabricate, and test the performance of an integrated robot weed control for removing weeds in greenhouses.

The Auto CAD software 2011 version 18.1 was used to design the robot weed control. The construction and schematic layout of the robot components are shown in Figures 1 and 2. The main design was an implement attached to the monorail that forms parts of the robot weed control.

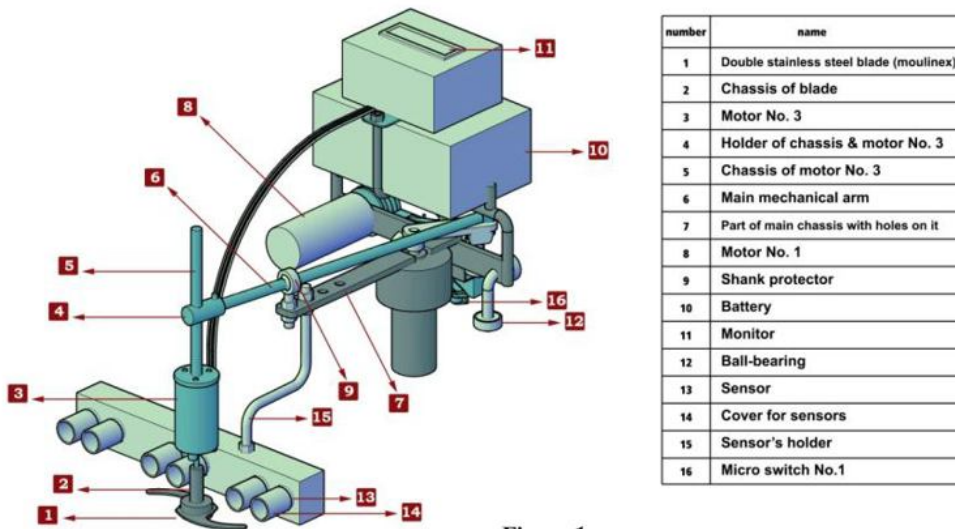

Figure 1a

Figure 1: the main components of the robot

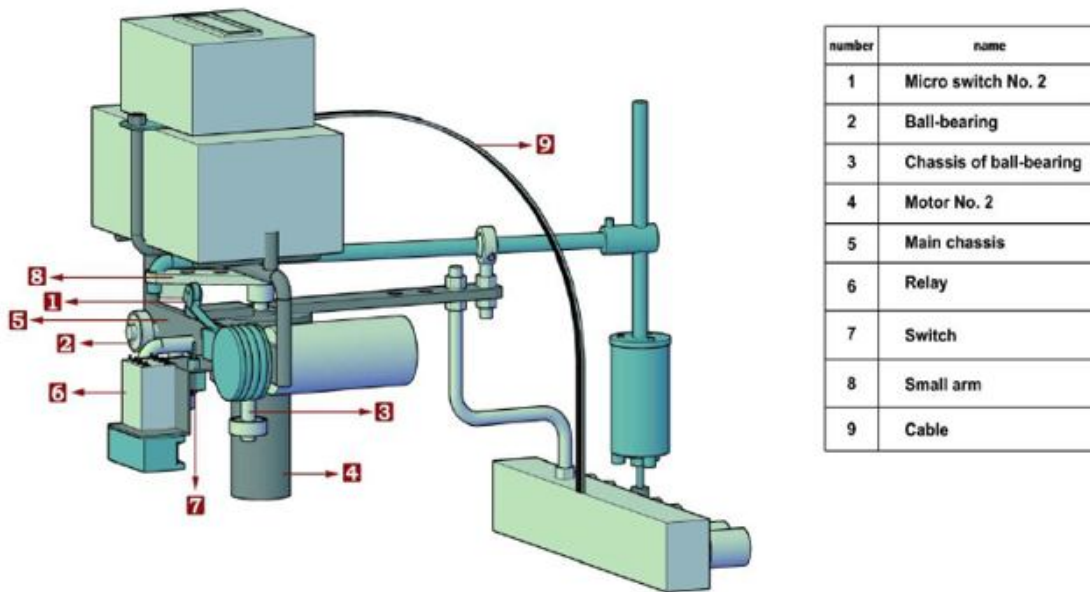

Figure 2 : The Schematic Diagram of the Designed Robot Weed Controlback view

Method of calculating the velocity and usage power of the movers

Movers whose blades are like circular sickles usually have two, three, or four blades, which are either smooth edge or are serrated. Figure 3.26 shows the direction of the tip of one of the blades (A tip) in a two-blade sickle. As it is observed, the tip of the blade shows a cycloid curve in the ground level (Figure 3).

W_B = Circular speed of blade (rad/s).

V_F = Forward moving speed of mover (m/s)

V_{bf} = The ratio of the total speed of blade to ground (m/s)

V_b = The circumferential speed of blade (m/s)

r_b = Radius of blade (m)

U = Direction of moving

V = Speed of blade (m/s)

When blades with the speed of W_B go around the circle or axle of sickle, this axle goes on with V_F speed and tips of the blades spend a cycloid curve. Speed of the tip of the blade to the ground is equal to coordinate sum of speed of move and its circumferential speed.

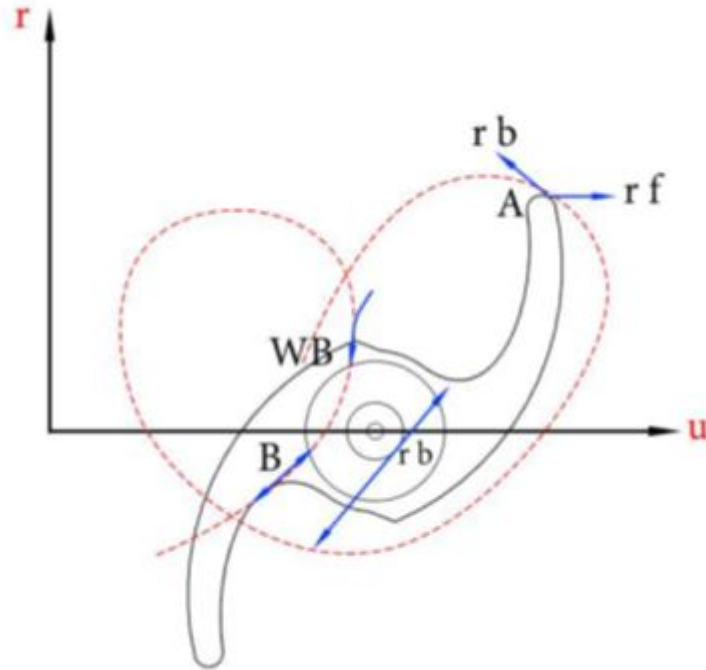

Figure 3 : Calculating the velocity of rotating blade in sickles,(Source: Behroozilar, 2000)

If the direction of moving is considered as U , the direction of the moving blade to the product is in the direction of V_{bf} and, and it changes in each moment and turns by rotating the blade. In this state, for achieving the components of U and V , speed of the blade tip can be written as component of blade speed in direction of moving U . (Behroozilar, 2000).

$$V_{bu} = V_b \cos(\pi/2 - \theta) = V_b \sin \theta$$

$$V_b \sin(WBt) = r_b WB \sin(WBt)$$

$$\theta = w \times t$$

$$V_u = V_f - V_{bu} = V_f - V_b \sin \theta = V_f - r_b WB \sin(WBt)$$

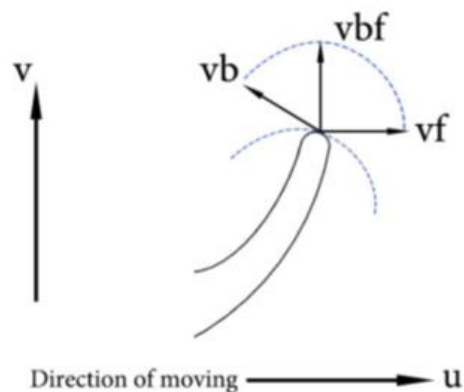

Figure 4 : Calculating U,(Source: Behroozilar, 2000)

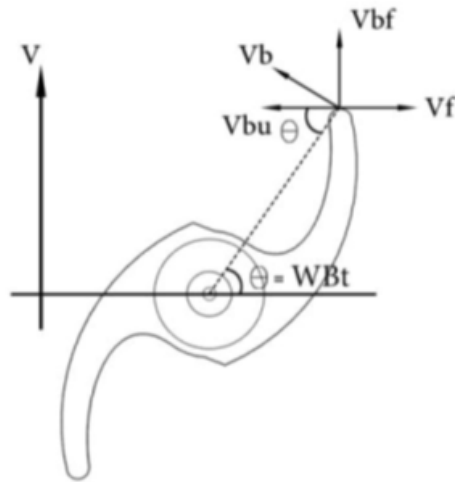

Figure 5 : Calculating V,(Source: Behroozilar, 2000)

The component of blade tip in direction V is obtained by:

$$V_v = V_b \cos \theta = r \omega \cos(\omega t)$$

θ = Angle between blade and movement direction = ωt

V_u and V_v based on (m/s)

t = measured time from point $\theta = 0$ (s)

Then based on features of the plant, the lowest velocity of the blade in the cutting strike is achieved. When the strike power is used for cutting stem, there is no antiblade and the stem is cut only by the stick of blade to the stem. In the cases when the blade does not exist, all support comes from the plant itself (antiblade job). This support is by bending the strength of the remaining plant in the cutting line and hardness of its torques that a part of plant over the level of cutting line is supplied.

Electronic sector of the robot

The electronic module of the robot consists of an ultrasonic sensors, a macro control motors and a LCD display as describe in Figure 2. It is composed of three main components:

1. Ultrasonic Sensors
2. Processor
3. LCD display

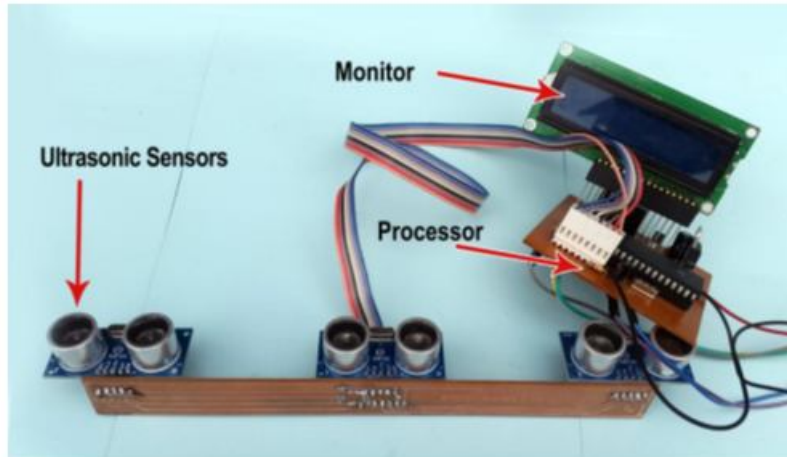

Figure 6 : Electronic modules of the robot

LCD Display

After the diagnosis of the weed, all the information in the processor is shown on the LCD screen. The information includes the distance between the weed and sensors and that which sensor identified the weed (Figure 3).



Figure 7: The monitor

In the design of electronic sector part, these points were considered:

1- Sound waves that transmission from transmitters of ultrasonic sensors are circular. Whereas these sensors are proximity (close) to the ground, and so that the waves do not hit the ground

immediately after the transmission, and do not confuse the ground as a obstacle (weed). It should changes the circular waves to linear waves, so it used a tube pipe cover for any of the ultrasonic sensors.

2- After starting to move the robot arm, the blade is in the range of the sensor signals, and the device recognize it as a weed. So the robot program has been designed to react the first pulse from sensors and do not consider the sensors blade just before the main arm start moving.

The Robot Work Principles

After switching the device on, the robot starts moving on the monorail which is along the greenhouse from one row to another. When the robot reaches the first stopper on the rail, it strikes the first micro switch (MSA) and the micro switch's roller passes over it. When the micro switch's roller is just over the stopper, the micro controller orders the first motor responsible for moving the robot on the rail to switch off; this causes the device to stop moving. When the device is placed precisely between the two plants and finds if there are any weeds, a signal indicating the existence of an obstacle (weed) is sent to processor part of the device, it is processed by the computer program to determine the distance between the obstacle and the sensors and whether the obstacle is identified with either the left, right, or middle sensors. Subsequently, it sends an order to the second motor responsible for moving the arm to work. The second motor is located under the small arm of the robot causing the circular movement of the small arm. The holes designed on the small arm enable the device to control the extent of the main arm's advance which is located on one of the small arm's holes. Given that the holes designed on the small arm are off-center, the small arm's circulation makes the large arm move back and forth. In order to keep the balance, the extent of the large arm's movement must be determined and control it precisely. The large arm is passed through a swiveling base that is fixed to the primary device chassis with a secondary one. On the secondary chassis, there are a number of holes designed to change the extent of the large arm's angle rotation simply by replacing the base. The reason for this change is that, in some greenhouses, the distance between the main plants is not always 40 centimeters. When the large arm starts moving forward, the device's blade enters the row between the plants and begins to cut the weed. This blade is attached to the third motor which is located at the end of the main arm on a perpendicular height adjustment chassis that can change its height from the ground. With one rotation of the small arm, the blade which is in horizontal triangle shape approaches the main plant from one side into the row and moves along the row between the plants until it reaches the second main plant then it exits from there. It means that if we imagine the large arm's route is a triangle, the arm on one of the sides, enters the row and on the axis passes the line between the main plants and exists from the other side of the triangle. It should be noted that the third motor is on when the robot is working; whether it moves or it stops. Since the greenhouse is a wet environment with suitable growth conditions, there is a lot of weed both in the margin of rows and when the device is orbiting so if the blade constantly works it can cut such weeds; therefore, the weed doesn't prevent the device from moving smoothly and it doesn't cause problems for transportation and workers' traffic later on. As soon as the small arm reaches the end of its first round, there is a stopper designed under it which activates the second micro switch. This micro controller orders the second motor to stop. As a result, the main arm which has already done its job and has left the rows stops moving. The micro controller then sends an order to the first motor, too.

Consequently, the device starts moving until it reaches the next stopper; thus, one complete cycle is completed.

Greenhouse Test

Three types of blades have 3 rotations of 3500, 2500, and 1500 for the best answer. The type of a blade with speed of 3500 rpm rotation/min and arm moving speed or the same speed of arm motor and 10rotation/min was achieved. To compare the efficiency between the blades, the rate of waste grass removal was expressed as a percentage.

Time and motion study

The time needed for the robot to move from one stopper to another

For motor No 1, the typical speed is 60rpm or 0.45 km/h

The wheel diameter is 4 cm.

$4 \times 3.14 = 12.56 =$ Surrounding of wheel, (cm)

$T = 3.6 \times X / VF$

Where,

T= time needed for the robot to move from one stopper to another (between two continues stopper), (s)

X= Stopper distance, (m)

VF= forward speed (km/h)

Assuming Vf =0.45 km/h (the minimum forward speed) and X=40 cm (distance between two continues stopper), then T=3.2s. The possibility for the robot to pass through the two stoppers within a row was considered for the consequent calculations.

Removing Time Used for One distance within two plants

For motor No2, the typical speed is 10rpm or 0.16 rps (s=second)

Therefore, for 1(Rotate)=6s

T=6s= Time needed for the robot to remove the weed (between two plants), (s)

The maximum number of weed (NW) in the greenhouse

The Weeds listed in Table 1. grow simultaneously with the plant throughout the growing year (October to April) when that greenhouse is working and exploits all the all facilities provided for the main crop (cucumber).

The greenhouse test procedure for the robot

The device was tested three times in the greenhouse. First, 15 days after the crop was cultivated in the ground and the weeds around them were also 15 days old. These weeds usually have thin and very flexible stalks and are 10 centimeters high. The second time was when the original plants were 2 months old and they were ready for producing cucumbers. The third stage was when the chassis was exactly in front of the main stem of the plant and the main stem was lying on that. Finally, the analysis of variance (ANOVA) and L.S.D tests were used to analyze the data using the statistical analysis systems (R) 2010 software.

Results and Discussion

Selection of cutting blades

Three types of blades were considered, the first type was S-shaped, the second type was triangular, and the third type was circular. These blades were selected due to their availability, low cost, and their performance during the initial test experiments. Each blade was tested with 3 rotations: 3500 rpm, 2500 rpm, and 1500 rpm while the speed of the main arm of the machine was 10 and 30 rpm (for example, the circular blade moved with 3500, 2500, and 1500 rpm and the speed of the main arm was 10 and 30 rpm. the selection of the Blade rotation (BR) speeds was based on the previously published results on rotary movers, and based on preliminary trial and errors. The type of a blade with speed of 3500 rpm and moving speed of arm or the same speed of arm motor and 10 rpm was achieved (Table 1) .

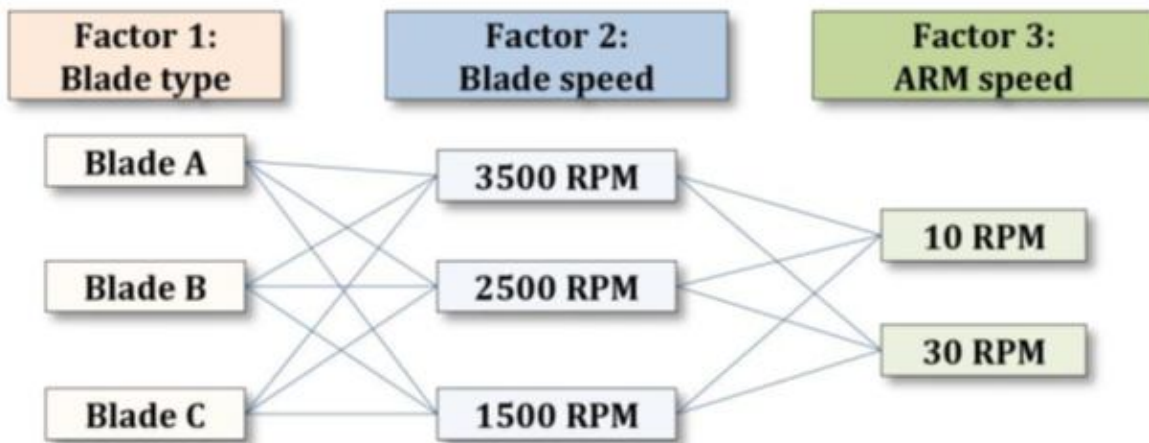

Figure 8 : Types of blade

To compare the efficiency between the blades, the rate of the weeds removal was expressed as a percentage. For example in using blade A with a speed of 3500 rpm and a moving arm speed of 10 rpm, the highest rate of removal was more than 95 percent of weeds removed. When the speed of moving the arm increased, then the rate of bending the weeds also increased and; consequently, the remaining weeds on the land were more frequent and longer. When the rate of the BR decreased to 2500 rpm and 1500 rpm, the rate of the precision lowered and a greater percentage of weeds were left uncut. Consequently, the lowest cutting that had none-monotonous remaining weeds were uncut weeds while the blade that was circular with the lowest rotation of 1500 rpm with at least 30 rpm was used that was about 45% of cut weeds and 55 percent of the remained weeds none-monotonously with unsmooth cutting level. Therefore, the percentage of cutting was between 45 percent and it changed by 95 percent in the best situation.

Table 1 : The weed detection System Test

Number	NW	Sense by sensor	Distance of weed from the sensor (cm)
1	2	L	15
2	1	L	8

3	8	L-M	30
4	12	L-R-M	5-13-13
5	3	R	18
6	0	Not detected	0
7	0	Not detected	0
8	5	M	11
9	2	L	14
10	9	L-R-M	8-15-37
11	1	M	21
12	6	R-M	13-17
13	2	R	9
14	20	L-R-M	16-20-7
15	18	L-R-M	20-20-17
16	17	L-R-M	6-10-9
17	1	R	7
18	0	Not detected	0
19	0	Not detected	0
20	0	Not detected	0
21	2	L	22
22	4	L-M	8-36
23	4	L-M	11-25
24	2	R-M	14-16
25	3	R	10
26	8	R-L	6-31
27	16	R-L-M	13-15-12
28	20	R-L-M	5-5-5
29	5	R-L-M	11-17-25
30	2	R	8

The percentage of weeds cut at 1500, 2500, and 3500 rpm for the three blade types, namely A, B, and C with the rotational speed of 10 and 30 rpm for the main arm are presented in Table 2.

Table 2 : The percentage of weeds cut in different blade type and different motor arm speed

Repetition	Bladetype	BR	The motor armspeed	The percentage of weeds cut	The NW
1	A	1500	10	60	8
1	A	2500	10	71	10
1	A	3500	10	85	11
1	A	1500	30	52	9
1	A	2500	30	60	8
1	A	3500	30	70	3
1	B	1500	10	55	5
1	B	2500	10	60	8
1	B	3500	10	77	7
1	B	1500	30	48	9
1	B	2500	30	60	9

1	B	3500	30	72	10
1	C	1500	10	53	9
1	C	2500	10	70	8
1	C	3500	10	80	0
1	C	1500	30	50	8
1	C	2500	30	59	10
1	C	3500	30	79	14
2	A	1500	10	65	12
2	A	2500	10	77	13
2	A	3500	10	87	5
2	A	1500	30	55	8
2	A	2500	30	68	9
2	A	3500	30	75	9
2	B	1500	10	55	8
2	B	2500	10	63	1
2	B	3500	10	80	7
2	B	1500	30	40	15
2	B	2500	30	69	12
2	B	3500	30	66	8
2	C	1500	10	55	10
2	C	2500	10	73	4
2	C	3500	10	81	9
2	C	1500	30	45	7
2	C	2500	30	63	2
2	C	3500	30	77	18
3	A	1500	10	58	20
3	A	2500	10	69	11
3	A	3500	10	95	10
3	A	1500	30	47	7
3	A	2500	30	57	3
3	A	3500	30	72	5
3	B	1500	10	52	9
3	B	2500	10	59	8
3	B	3500	10	85	10
3	B	1500	30	45	9
3	B	2500	30	53	6
3	B	3500	30	73	4
3	C	1500	10	49	1
3	C	2500	10	69	0
3	C	3500	10	84	11
3	C	1500	30	42	8
3	C	2500	30	69	9
3	C	3500	30	70	7

The average percentage of weeds cut at 1500, 2500, and 3500 rpm for the three bladetypes, namely A, B, and C with the rotational speed of 10 and 30 rpm for the main armare presented in Table 3.

Table 3 : The average percentage of weeds cut in different blade type and different motor arm speed

Average cut weed blade A	Motor arm speed 10	1500BR 61%	2500BR 72.3%	3500BR 89%
Average cut weed blade A	Motor arm speed 30	1500BR 51.33%	2500BR 61.66%	3500BR 72.33%
Average cut weed blade A	Motor arm speed 10	1500BR 54%	2500BR 60.66%	3500BR 80.66%
Average cut weed blade A	Motor arm speed 30	1500BR 44.33%	2500BR 60.66%	3500BR 70.33%
Average cut weed blade A	Motor arm speed 10	1500BR 52.33%	2500BR 70.66%	3500BR 81.66%
Average cut weed blade A	Motor arm speed 30	1500BR 45.66%	2500BR 63.66%	3500BR 75.33%

Automation system

Automatic weeding was carried using the robot consists of ultrasonic sensor that sense the presence of weeds between the cucumber plant. For the experiment, when the sensors sense the weeds, the mechanical cutter will receive the signal to move and cut the weeds. Either one of the ultrasonic sensor sense a signal weed, the mechanical weeder will operate initially the ultrasonic right (R) or left (L) or middle (M) detect the weed. For area, no ultrasonic sensor sense the weed, so the mechanical cutter will not operate. The weed detection System was tested thirty times when the robot stopped between two cucumber plants in the greenhouse. Table 4. shows the distance between the weeds and the sensors and whether the weed is identified (sense) with either the left (L), right (R), or middle (M) sensors.

Computing the different width for the machine

As can be seen in Figures (9) and (10), there are 3 holes on the small arm of the machine and there are 4 holes on the chassis of the device based on the location of the fulcrum arm machine.

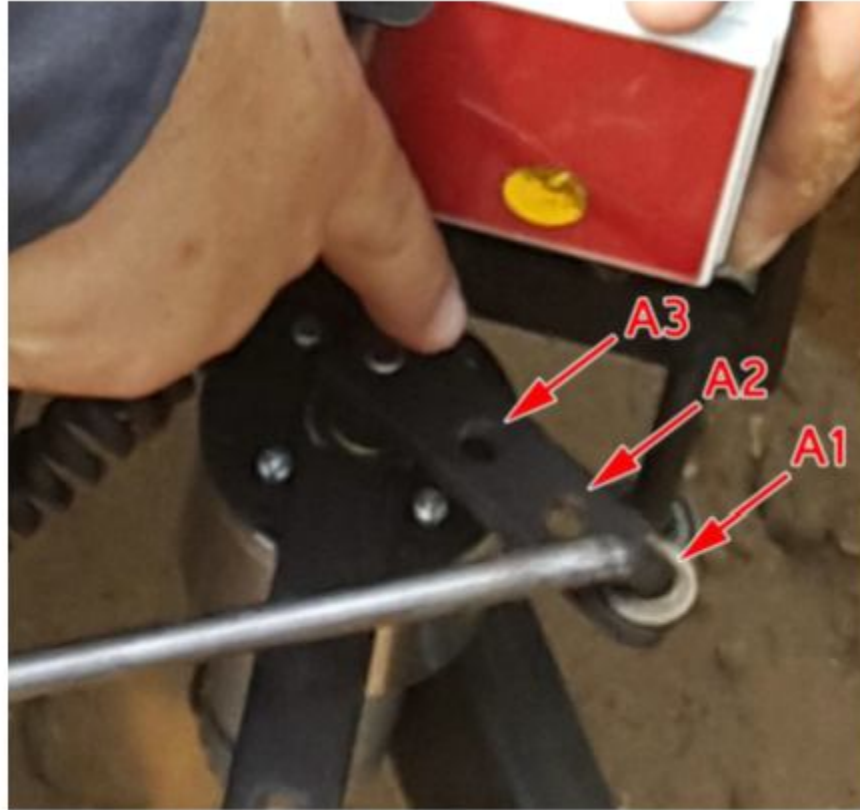

Figure 9 : Three holes on the small arm of the machine

The holes were made on the small arm of the machine so as to change the width of the working machine, so that the device would be able to move and use the holes in each of the 12 transverse distances between the two main plants to cut the weeds. Therefore, if greenhouse owners may want to change the distances between two plants on a row (except for 40 centimeters) or plant another product except cucumber whose distance from another plant is different from that of cucumber plants, it can easily be achieved by placing the arm in another hole in the base of the arm or the long arm (original) to change the working width.

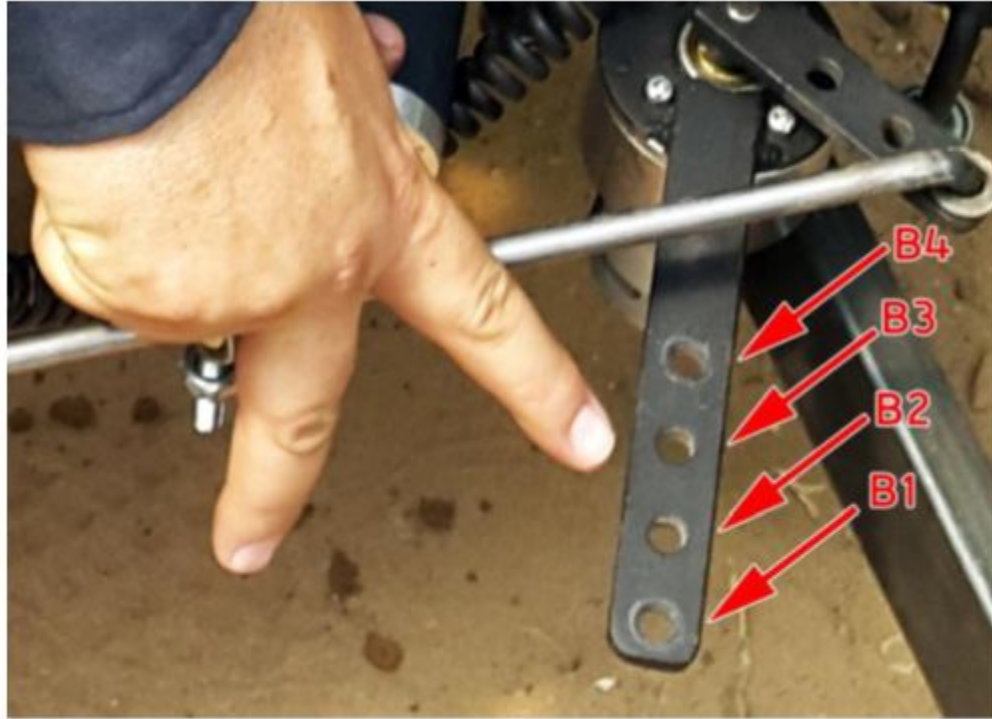

Figure 10 : Four holes on fulcrum arm of the machine

All these holes, either on the arm or on the chassis, will lie within 2 cm from each other. Table 4 shows distance between center of holes and center of motor shaft.

If the present holes on the short arm (3 holes) are called A_1 , A_2 , and A_3 and the chassis holes (4 holes) are called B_1 , B_2 , B_3 and B_4 , the following cases arise:

(A_1-B_1) , (A_1-B_2) , (A_1-B_3) , (A_1-B_4)

(A_2-B_1) , (A_2-B_2) , (A_2-B_3) , (A_2-B_4)

(A_3-B_1) , (A_3-B_2) , (A_3-B_3) , (A_3-B_4)

The length of the small arm is 70 mm. (From the junction to the motor arm to the bottom) that rotates around his arm where the arm is connected to the motor. Thus, the short arm rotates round a circle with a diameter of 140 mm or 14 cm. If the distance between the centers of the last hole on the short arm (A_1) and the motor shaft of the motor is considered 65 mm, in the last hole of the small arm, the main arm (A_1) rotates round a circle with a diameter of 130 mm or 13 centimeters over it. As the distance between the holes is 20 mm or 2 centimeters, if the second hole A_2 is used, the diameter will be 90 mm or 9 centimeters. If the latest hole (A_3 the nearest hole to the shaft) is

used, the circle with a diameter of 50 mm or 5 centimeters will be traversed.

2- The small motor arm which moves the big arm is also connected to a part of the chassis. At the end of this part of the chassis, there are a number of holes on which the base of the main arm is placed. The distance between this part of the chassis and the motor pivot arm is considered approximately 150 mm.

As previously mentioned, 4 holes on the side of the chassis is designed. The distance from center-to-center of them is 20 mm or 2 centimeters.

If the base of the main arm is placed on the last hole on the chassis (B_1) the distance from the motor shaft will be considered 150 mm. If it is placed in the second hole (B_2), the distance from

the center of the motor shaft will be 130 mm, on the third hole (B₃), it will be 110 mm and, in the hole (B₄), the distance from the motor shaft will be 90 mm or 9 centimeters.

3- In this design, the distance between the long arm of the system and the central hole that the base of the motor is placed on is considered 350 mm or 35 centimeters.

4- If the arm is placed in the hole A₁, the main arm in the hole B₁, and the small arm is completely in the vertical position with the chassis that the base of arm is placed in its holes, a right triangle is created that two sides of it is clear. It is the triangle A₁B₁D (All measures are in mm units).

$$c^2 = a^2 + b^2 \Rightarrow c^2 = (65)^2 + (150)^2 \Rightarrow c^2 = 4225 + 22500 \Rightarrow c^2 = 26725$$

$$\Rightarrow c = 163.47\text{mm} \approx c = 164\text{mm} \Rightarrow A_1B_1 = 164\text{mm}$$

Because A₁ B₁ is part of the big arm, the remaining part of the big arm (the main part) will be equal to:

$$350 - 164 = 186 \text{ mm}$$

If the small arm moves a full semicircle, the right triangle will change to isosceles triangle with sides of:

$$A_1B_1 = 164\text{mm}$$

$$EB_1 = 164\text{mm}$$

$$A_1E = 130 \text{ mm diameter}$$

Both sides A₁, B₁, and B₁ E are parts of the main arm of the machine. However, in this case, they are considered along the main arm.

Another triangle will be created on the top of the triangle A₁B₁E called B₁FG. Calculating the length of FG, which represents the distance between two points of the rotating arm, the width of the working machine can be created. In this triangle, B₁G equals B₁F so it is an isosceles triangle and the angles α and β are equal, as a result, the triangles A₁B₁E and B₁FG are similar.

The similarity of the two triangles can be written:

$$A_1B_1 / B_1G = B_1E / B_1F = A_1E / FG \Rightarrow 164 / 186 = 164 / 186 = 130 / FG \Rightarrow FG = 130 \times 186 / 164 = 147.43 \Rightarrow FG \approx 147$$

Since the beginning of the long arm is placed right in the axis of the cutting blade, two radius of the blades should be added to the both sides of FG side of the triangle. The cutting width of the machine in using the holes (A₁ B₁) is then achieved.

$$\text{So: } FG = 147$$

$$\text{The width of cutting} = FG + r + r \Rightarrow 147 + 50 + 50 \Rightarrow$$

$$\text{The width of the machine in position 1 (A}_1 \text{ B}_1) = 247\text{mm.}$$

Table 4 : Distance between center of holes and center of motor shaft

Number	Holes name	Distance from the center of motor
1	A1	65mm
2	A2	45mm
3	A3	25mm
4	B1	150mm
5	B2	130mm
6	B3	110mm
7	B4	90mm

Uncertainty in the proper functioning of the machine

While designing this machine, it was assumed that the cucumbers greenhouse should be fully mechanized and should be based on the scientific planting maintenance, and harvesting. Unfortunately, farmers ignore or change all or parts of the principles to reduce their costs and this can result in some problems. Here's a summary of some of them.

1- As can be seen in Figure 5, moving in the aisles between the rows is in the way so that at the time of land preparation, planting, and seeding between the rows, every other two rows must use one aisle, which could also be used for the weeding and harvesting as well as using two rows of monorail. However, farmers who tend to use a larger part of their greenhouse environment do not adhere to this principle.



Figure 11 : Moving in the aisles between the rows is in the way

2- As can be seen in Figure 6, during the preparation, the manure from the livestock is used on the rows of the plants to grow better. Manure spills are usually stacked in rows, and the seed is planted in the middle. This stack has a rough surface and is curved shaped. Similarly, weeds grow on it. Since the blade surface is smooth, it should be perfectly flat before seeding the surface of the curve.



Figure 12 : The rough surface and curved shaped

3- After the fifth leaf grows, the leaves down the stem should be cut due to aging and discoloration of stems, and should be taken away from the greenhouse. Most of the farmers avoid doing this due to the high labor costs of this action. Since these leaves are close to the surface of the ground, they will cause trouble for the blades.



Figure 13 : The plant tilted and start to grow horizontally

4- While using the chassis of the greenhouse, it should be considered that the bases of the chassis are placed completely in the soil exactly in front of stem of the plant (at a distance of 40 cm from each other). A number of the farmers, however, pay no attention to this. Given that they don't use these chassis, they place them farther from each other. In so doing, the blade may touch them and consequently be damaged.



Figure 14 : Wrong Position between the chassis and plants

Conclusion

The main objective of this research was to design and develop a robotic system to control weeds in cucumber greenhouses without using chemical materials. In this study, a robot weeder was designed and fabricated that can move between the rows on a monorail in the greenhouse. The arm of this robot has the ability to go in the space between the plants and cut the weeds. Based on the study the following can be concluded. The robot was successfully designed and tested in a greenhouse and managed to remove about 89% of weed. In this study a mechanical robot was designed that can move between the rows on a monorail in the greenhouse. The arm of this robot has the ability to go in the space between the plants and cut the weeds. Six engine speeds of 30-40-50-60-80- 120 rpm were tried to test the proper speed. After various tests on each of the motors 50 and 60 rpm were selected. Both seemed to work well for the robot, but since one of the objectives of the study is to cut the weeds in the minimum time, the engine speed was 60 rpm, so a shorter time interval between the two main plants is used. To select the best arm speed, two motors with speeds of 10 and 30 rpm were used. Since the study results indicated that as much as the speed of the engine is further, the percentage of cut weeds reduces, therefore, the

motor of 10-rpm was selected to move the arm. To choose the best type of blade, three blade types of A (Moulinex), blade B (triangular) or C (circular) were used. The average percentage of cut weeds by the blades had significant differences. After selecting three types of blades A, B, C, each was investigated in the three speeds, 1500, 2500 and 3500 rpm. The highest and the lowest cut weeds were obtained in use of the 3500 rate and in 1500 rpm for the rotating blade.

The main objective of this research was to design and develop a robotic system to control weeds in cucumber greenhouses without using chemical materials. In this study, a robot weeder was designed and fabricated that can move between the rows on a monorail in the greenhouse. The arm of this robot has the ability to go in the space between the plants and cut the weeds. Based on the study the following can be concluded. The robot was successfully designed and tested in a greenhouse and managed to remove about 89% of weed. In this study a mechanical robot was designed that can move between the rows on a monorail in the greenhouse. The arm of this robot has the ability to go in the space between the plants and cut the weeds. Six engine speeds of 30-40-50-60-80-120 rpm were tried to test the proper speed. After various tests on each of the motors 50 and 60 rpm were selected. Both seemed to work well for the robot, but since one of the objectives of the study is to cut the weeds in the minimum time, the engine speed was 60 rpm, so a shorter time interval between the two main plants is used. To select the best arm speed, two motors with speeds of 10 and 30 rpm were used. Since the study results indicated that as much as the speed of the engine is further, the percentage of cut weeds reduces, therefore, the motor of 10-rpm was selected to move the arm. To choose the best type of blade, three blade types of A (Moulinex), blade B (triangular) or C (circular) were used. The average percentage of cut weeds by the blades had significant differences. After selecting three types of blades A, B, C, each was investigated in the three speeds, 1500, 2500 and 3500 rpm. The highest and the lowest cut weeds were obtained in use of the 3500 rate and in 1500 rpm for the rotating blade.

The analysis of the interaction of the blade speed and blade type showed that (a) none of the mutual interactions was significant in the variance test. (b) t-test showed that if the rotational speed of the blade was low, the blade type would have a significant effect on the NW cut. (c) The increase in the blades 'rotational speed, the efficiency of the blades did not change significantly. (d) For all the blade types, the highest percentage of the weeds cut was at 3500 rpm. Studying the interactive effect of blade rotational speed and the motor arm speed indicated that if the speed of the motor arm is 10rpm and the blade rotational speed is 3500 rpm, percentage of cut weed will be maximized and that the lowest percentage occurred in the blade rotational speed of 1500 rpm and 30 rpm speed of the motor arm. In each motor arm speed, the increase in the rotational blade speed caused an increase in percentage of cut weeds. If the motor arm speed is increased in each rotational blade speed, the percentage of cut weeds will decrease. The comparison of the interactions between the three different types of blades, blade speed and the speed of the arm demonstrated that the most percentage of the cut weeds was obtained when the Moulinex blade at the rotational speed of 3500 rpm was used and engine speed was 10rpm. The lowest percentage of cut weeds was obtained when the blade speed was 1500 and the speed of motor arm was 10 rpm and the blades types were triangular and circular. Regarding the speed of the machine and also the speed of the motor arm from the time it stops on the first stopper, up to the end of a cycle and it takes 10 seconds for restarting of the machine to the next stopper and the next cycle.

It can be recommended that since most of the greenhouse farmers have the low literacy, they will refuse to use a complicated system. Because they are always worry that having a mistake in using the system will cause their product to be damaged, so it should be tried to offer them a

simple system not a complicated one. Low cost is one of the ways that we can put a new idea into a community, especially in the farmers' community. Therefore, in designing of this system it was tried to use the simplest methods and technologies. The major impact of this research is that farmers can benefit from the advantages of a robotic weed control system that would facilitate and speed up removing the weeds, thereby increasing their income and decreasing the cost of cucumber production.

Furthermore, it is expected that the best robot weed control assist greatly in reducing labor requirement, fuel consumption, the weeding time, and expanding the new idea on using new technology and work successfully on the greenhouse. Current multiplepass removing operations could be replaced with a single pass operation.

It can be recommended that since most of the greenhouse farmers have the low literacy, they will refuse to use a complicated system. Because they are always worry that having a mistake in using the system will cause their product to be damaged, so it should be tried to offer them a simple system not a complicated one. Low cost is one of the ways that we can put a new idea into a community, especially in the farmers' community. Therefore, in designing of this system it was tried to use the simplest methods and technologies. The major impact of this research is that farmers can benefit from the advantages of a robotic weed control system that would facilitate and speed up removing the weeds, thereby increasing their income and decreasing the cost of cucumber production.

Furthermore, it is expected that the best robot weed control assist greatly in reducing labor requirement, fuel consumption, the weeding time, and expanding the new idea on using new technology and work successfully on the greenhouse. Current multiplepass removing operations could be replaced with a single pass operation.

References

1. Borenstein, J.; Everett, H.R.; Feng, L. (1996). *Navigating Mobile Robots. Systems and Techniques*, 1st ed.; A.K. Peters, Ltd.: Wellesley, MA, USA.
2. Cho, S. I., Lee, D. S. and Jeong, J. Y. (2002). Weed-plant Discrimination by Machine Vision and Artificial Neural Network. *Biosystems Eng.*, 83 (3): 275–280.
3. Dario, P., G. Sandini, B. Allotta, A. Bucci, F. Buemi, M. Massa, F. Ferrari, M. Magrassi, L. Bosio, R. Valleggi, E. Gallo, A. Bologna, F. Cantatore, G. Torrielli, and A. Mannucci. (1994). The Agrobot Project for greenhouse automation. *Acta Hort. (ISHS)* 361: 85-92.
4. Giacomelli G.A., and Ting K.C. (1995) \Transportation and Robotics for greenhouse Crop Production Systems", *Acta Hort (ISHS)*, Vol 399, pp. 49-60.
5. González. R., Rodríguez. F., Sánchez-Hermosilla. J., G. Donaire. J. (2009). Navigation techniques for mobile robots in greenhouses. *Applied Engineering in Agriculture*. Vol. 25(2): 153-165. American Society of Agricultural and Biological Engineers.
6. Hopkins, M. (2000). Automating in the 21st Century Career and Technical Education", *Greenhouse Grower*, pp. 4-12.
7. Kondo, N., and K. C. Ting. (1998). Robotics for plant production. *Artificial Intelligence Review* 12: 227-243.
8. Mandow, A.; Gómez de Gabriel, J.M.; Martínez, J.L.; Muñoz, V.F.; Ollero, A; García-Cerezo, A. (1996). The autonomous mobile robot Aurora for greenhouse operation. *IEEE Robot. Auto. Mag.*, 3, 18–28.
9. Pilarski, T., Happold, M., Pangels, H., Ollis, M., Fitzpatrick, K., Stentz A. (2002). The Demeter System for Automated Harvesting", *Autonomous Robots*, Vol 13, pp. 9-20.
10. Sánchez-Hermosilla, J.; Rodríguez, F.; González, R.; Guzmán, J.L.; Berenguel, M. (2010). A Mechatronic Description of an Autonomous Mobile Robot for Agricultural Tasks in Greenhouses. In *Mobile Robots Navigation*; Barrera, A., Ed.; InTech.: Rijeka, Croatia,; pp. 583–608.
11. Sandini, G., F. Buemi, M. Massa, and M. Zucchini. (1990). Visually guided operations in greenhouses. *IEEE Intl. Workshop on Intelligent Robots and Systems*. Piscataway, N.J.: IEEE.

12. Sezen, B. (2003), Modelling Automated Guided Vehicle Systems in material Handling", Dogus Universitesi Dergisi, Vol 4, No. 3, pp. 207-216.
13. Subramanian, V., T. F. Burks, and S. Singh. (2005). Autonomous greenhouse sprayer vehicle using machine vision and ladar for steering control. Applied Eng. in Agric. 21(5): 935-943.
14. Van Henten, E.J. Van Tuijl, B.A.J. Hoogakker, G-J. Van Der Weerd, M.J .Hemming, J.J. Kornet, J.G and Bontsema, J (2005). An Autonomous Robot for De-leafing Cucumber Plants Grown in a High-wire Cultivation System, Greenhouse Technology Group, Agrotechnology & Food Innovations Ltd. P.O. Box 17, NL6700 AA Wageningen The Netherlands.
15. Zhu, B., Jiang, L., Luo, Y. and Tao, Y. (2007). Gabor Feature-based Apple Quality Inspection Using Kernel Principal Component Analysis. J. Food Eng. 8(4): 741-749.

UNDER PEER REVIEW