

# TEMPERATURE COMPENSATION OF LOW-COST SENSORS FOR ACCURATE TEMPERATURE MEASUREMENT

## **Abstract:**

Temperature measurement plays a key role in various industrial, scientific, and agricultural applications. The study investigates the performance of three temperature humidity sensors. DHT11, DHT22 and LM35. The sensors are analyzed under different conditions, including compensation, and with a temperature compensation algorithm, and with proportional P and proportional-integral-derivative PID controllers. Sensors are interfaced with a Raspberry Pi 4B model. The sensors were tested in controlled environments with temperatures ranging from 10 degrees to 100 degrees C, and their accuracy was evaluated by comparing their outputs with the reference values. Results revealed that the error percentages for all sensors exceeded permissible limits when used outside their specified ranges. Incorporating temperature compensation algorithm and P and PID controllers significantly improved measurement accuracy, reducing error percentages and root mean square errors (RMSE) across all sensors. Out of the three sensors, LM35 demonstrated a 5-fold reduction in error percentage at higher temperatures compared to other methods.

**Keywords:** DHT11, DHT22, LM35, Raspberry PI 4B model, temperature compensation algorithm, root mean square error

## **Introduction:**

Temperature is expression for denoting a physical condition of matter, similar to how mass, dimensions and time are expressed. Heat is a form of energy associated with the continuous motion of minute particles present in every state of matter. Thus temperature is measure of

that energy known as heat. The range of temperature within the universe lies in the range of near zero of black space to billions of degrees of nuclear fusion. This is the tremendous range of temperature variation, hence no single sensor is able to measure such wide range of temperature. Selection of the sensors is based on the temperature range to be measured, the environment for it is used and the economical constraints. There are many ways of how temperature can be measured and numerous sensors are available according to the range and the transduction principle. The table below summaries the types of sensors available<sup>[1]</sup>  
[2].

Type of sensor	Transduction principle	Temperature range	Applications	Advantages	Disadvantages
Traditional filled system like liquid in glass thermometer	Expansion of filled system on application of temperature	-300 deg to 538 deg C	Heating, ventilation, air conditioning in industrial applications	Easy to construct	The filled substance are generally toxic like mercury, gas filling is also disappeared as it requires large size bulb if temperature is increased beyond

					ambient.
Bimetallic thermometers	Change of metallic volume due to change in temperature, the change coefficient is different for two metals.	100 deg to 550 deg C	Industrial temperature measurement	Less subject to breakage, lower cost and simplicity in design	Rough handling changes their calibration. Confined to local measurement.
Color indicators, crayons, pellets	Change in original color of material when certain temperature value is reached	40 deg C to 1371 deg C	Determining temperature of solid objects in oil	Sensors with different temperature ratings are available	Such type of indicators are highly expensive and used in industry where only end point is to be noted.
Fiber optic thermometers	Absorption of infrared energy by glass fiber	260 deg C to 3000 deg C	Temperature measurement of hot corrosive	Small size sensor, wide range, fast response,	High cost of measurement.

	and total internal reflection		moving and fragile materials. Medical hyperthermia , engine heads, polymer melting.	provide temperature profiles through noninvasive remote measurements of objects immersed in liquid	
Quartz crystal thermometry	Change in resonant frequency in response to change in temperature	-80 deg C to 250 deg C	Temperature and temperature difference measurements usually in laboratory	Good accuracy, excellent short term stability, one second response time	Expensive, best used in laboratory environment.
Thermistor	Negative coefficient of temperature resistance, i.e. resistance	-60 deg to 25 deg C	Widely used in temperature measurement in industries,	Relationship between temperature and resistance is	Covers limited temperature range, current

	decreases as temperature increases. Generally semiconductor materials is used		control of temperature and temperature compensation.	linear, response time is fast.	source is required, material used possess problem of self-heating.
Integrated circuit temperature transducers	The measured temperature is directly proportional to the output voltage or current produced during the measurement. Integration of electronics circuitry and primary sensing	-50 deg C to 150 deg C	Used in defence, industrial and commercial measuring of temperature	The relationship between corresponding temperature and voltage of current is highly linear, it is generally inexpensive	Measuring temperature upper limit is less than 200 deg C. power supply is required, available in limited configuration.

	element is achieved.				
--	----------------------	--	--	--	--

Table 1. Comparison between different types of temperature sensors.

From the comparison table it is clear that cost effective technique for measurement of temperature is using integrated circuit temperature sensors or transducers. In this research article DHT11, DHT22, LM35 sensors are studied, analyzed and compared.

It is estimated that over 70% of fresh water globally is used for irrigation purpose<sup>[3]</sup>. The crops produced through irrigation annually shows increase of 1.3%<sup>[4]</sup>. Food production in the developing world, notably in South, Southeast and East Asia, is at present heavily reliant on irrigation. The total irrigated area in Asia is 230 million ha, which represents over 70% of the global irrigated area. Of the 230 million ha of irrigated land area, 60% is located in China and India<sup>[5]</sup>. It has been found out that India uses 4 times water to produce one major unit of crop as compared to US or Europe<sup>[6]</sup>. This means that if efficiency in water use is achieved then 50 percent of the water conservation can be target reached in upcoming years. Conventional irrigation method involves uniform supply of water to every part of the field without taking into account of the spatial variation of the soil and crop water demand. This leads to over and under irrigation. Thus irrigation has to be performed precisely to reduce environmental impacts and asses the crop-water demands. The advantages associated with precision irrigation include increased crop yields, improved crop quality, improved water use efficiency/savings, reduction of energy costs and reduction of adverse environmental impacts<sup>[7]</sup>. For assessing the crop water requirement two approaches can be considered, real time monitoring of the soil moisture and determining the ET value from the ambient temperature data available. ET which is known as evapotranspiration is indicative of the

amount of daily water use by the crop<sup>[8]</sup>. The ET process is largely based on solar radiation, vapor pressure at any given time and wind speeds. It is also influenced by soil water content, the rate at which water can be taken out from the soil by plant roots<sup>[9]</sup>. The United Nations Food and Agriculture Organization Penman–Monteith (FAO-PM) equation gives the procedure of calculating the hourly or daily ET value using temperature data, humidity, wind speed, solar radiation<sup>[10]</sup>. The temperature data can be obtained by daily metrological data or by integrated circuit type of sensors. There are numerous types of temperature sensors ICs available based on their requirement, ratings. In this article three temperature sensors available with package ICs and datasheets are selected and the recording of temperature data is done and analysis is carried out.

## **Materials and Method**

Three different types of temperature humidity sensors with Raspberry Pi are selected for continuous monitoring of temperature. Raspberry Pi is a low cost, credit-card sized computer which plugs into a computer monitor or TV, and requires a standard keyboard and mouse. Raspberry Pi is a dynamic microcontroller and runs with the Python programming language<sup>[11]</sup>. The Raspberry Pi used is Raspberry Pi 4B model. Temperature sensors used are DHT11, DHT22 and LM35 which are three terminal ICs. The three different sensors are to be interfaced with Raspberry Pi by using GPIO pins of Raspberry Pi<sup>[12]</sup>. In the first method the sensors with entire setup are placed in controlled temperature chamber where the temperature is increased in the step of 5 degrees C. For data collection, the real-time temperature data is sent to AdafruitIO cloud. Adafruit is a cloud server that is specially developed for internet of things projects. It provides various statistical tools on single clicks. The data of parameters are moved over cloud. Multiple post operations are performed on

data over cloud and mobile application also access data from cloud<sup>[13]</sup>. The temperature record is taken on every 10 degrees rise in temperature. The starting point of recording of data is done from 10 degree C and the end point is at 100 degrees C. The data has to be analysed according to the parameter mentioned in the data sheet of the temperature sensor IC available<sup>[14] [15] [16]</sup>. The comparative table of three IC according to their specifications is given below<sup>[14] [15] [16]</sup>.

Specifications	DHT11	DHT22	LM35
Temperature range	0 to 50 degrees C	-40 to 80 degrees C	-55 to 150 degrees C
Temperature Accuracy	2 degrees C	0.5 degrees C	0.5 degrees C at 25 degrees C
Operating voltage	3 to 5.5 V DC	3 to 6 V DC	4 to 30 V DC
Output	Digital output via pin	Digital output via pin	Analog voltage proportional to 10mV/degree C

Table 2: Comparison of specifications of DHT11, DHT22, LM35 temperature sensors.

The experimental setup is given by the block diagram given below.



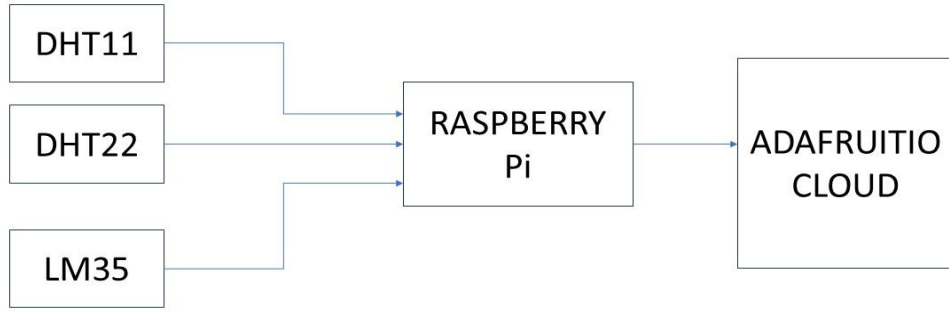

Figure 1: Experimental setup for the measurement and monitoring of temperature.

Figure 1: Block diagram for experimental setup

The readings that are recorded on IoT platform are compared with the actual values of the temperature that are available from the temperature-controlled chamber. The statistical analysis is performed and parameters for obtaining temperature compensation are calculated. In the second method, compensation algorithm is embedded into Raspberry Pi by incorporating correction factor for every temperature range<sup>[17]</sup>. The correction factor has to be calculated on the basis of temperature data obtained from the first method<sup>[18]</sup>. The correction factor is given as:

$$T_{corrected} = G \cdot T_{measured} + O$$

$$G = \frac{\Delta T_{reference}}{\Delta T_{measured}}$$

$$O = T_{reference} - G \cdot T_{measured}$$

$$G = \frac{T_{reference2} - T_{reference1}}{T_{measured2} - T_{measured1}}$$

$$O = T_{reference1} - (G \cdot T_{measured})$$

In the above equations,  $T_{corrected}$  is the temperature value after applying compensation algorithm,  $G$  is the gain and  $O$  is the offset.  $\Delta T_{reference}$  is the temperature difference between the reference set of temperature and  $\Delta T_{measured}$  is the temperature difference between the measured set of temperature.

The sensor arrangement is again placed into the temperature control chamber the temperature of the chamber is increased from 10 degree C to 100 degrees C. The data is sent to AdafruitIO cloud where it is stored and recorded for further statistical analysis. The figure below is the block diagram representation of the second method.

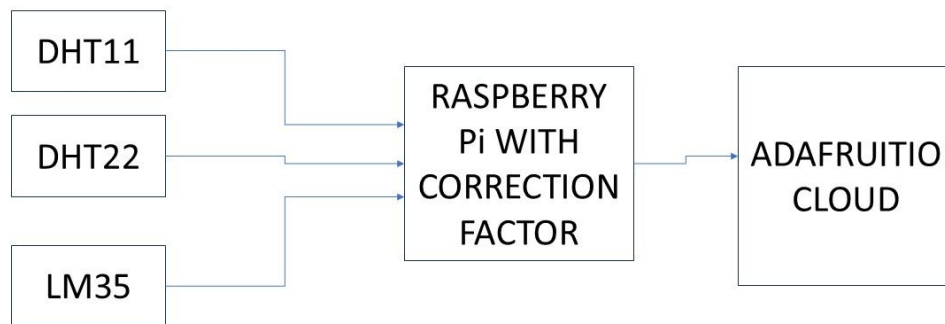

Figure 2: Experimental setup for the measurement and monitoring of temperature with correction factor.

Figure 2: Block diagram for experimental setup with temperature compensation algorithm

For the third method, compensation of temperature is achieved using the hardware set-up of operational amplifier and external circuits. AD823 operational amplifier IC is used in this regard. The AD823 is a precision operational amplifier designed by Analog Devices. It is commonly used in applications where low power consumption and small size are crucial. It

has low power consumption around 350 micro ampere, low offset voltage typically around 50 micro volt. It is 8 pin IC providing outstanding output dynamic range. It can operate from 1.8 V to 36V range<sup>[19]</sup>. Two types of controlling circuits are designed. First one is the Proportional type (P) and second one is the Proportional Integral Derivative type (PID). Designing parameters for P type controller are determined mathematically. Designing parameters for PID type controller are determined using Ziegler Nichols algorithm<sup>[20]</sup>. The parameters of PID type of controller are determined by DHT11 and DHT22 temperature sensor ICs digital ICs, direct temperature and humidity readings can be displayed with their deployment. While LM35 IC is analogue type, the output of this sensor is in terms of analogue value which is 10mV/C which is converted internally in proportion to corresponding ambient temperature<sup>[14] [15] [16]</sup>. For DHT11 and DHT22 IC digital to analogue convertor IC TiDAC8775 is being used as the output of both ICs is digital in nature. Only P type of controller is used for compensation of DHT11 and DHT22 ICs. For LM35 both the P and PID type controller are used for temperature compensation. TIDAC8775 is a 16-bit quad-channel programmable digital to analogue convertor from Texas Instruments designed for both current and voltage applications. It dynamically adjusts power consumption based on operational requirements and supports a Serial Peripheral Interface for easy integration with micro-controller and processors. It is generally used in industrial process control, signal simulation and data acquisition system<sup>[21]</sup>. For the temperature data recorded from the three methods error of measured data and Root Square Mean Error (RMSE) is recorded for statistical analysis. Block diagram for temperature compensation using P and PID controller is given below.

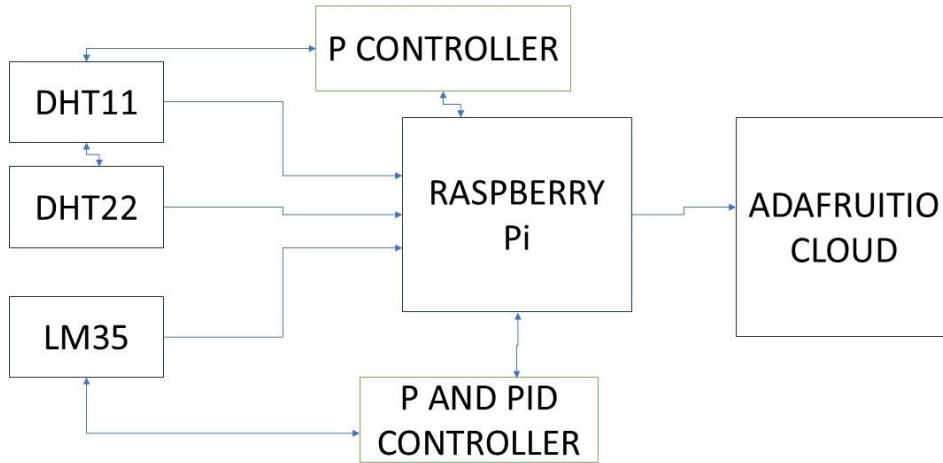

Figure 3: Experimental setup for the measurement and monitoring of temperature with P and PID controller.

Figure 3: Block diagram for experimental setup with P and PID controller

**Results and observations:**

On application of three sensors for temperature measurement and analyzing of the data.

Following variations are observed. The following graphs are shown In this regard.

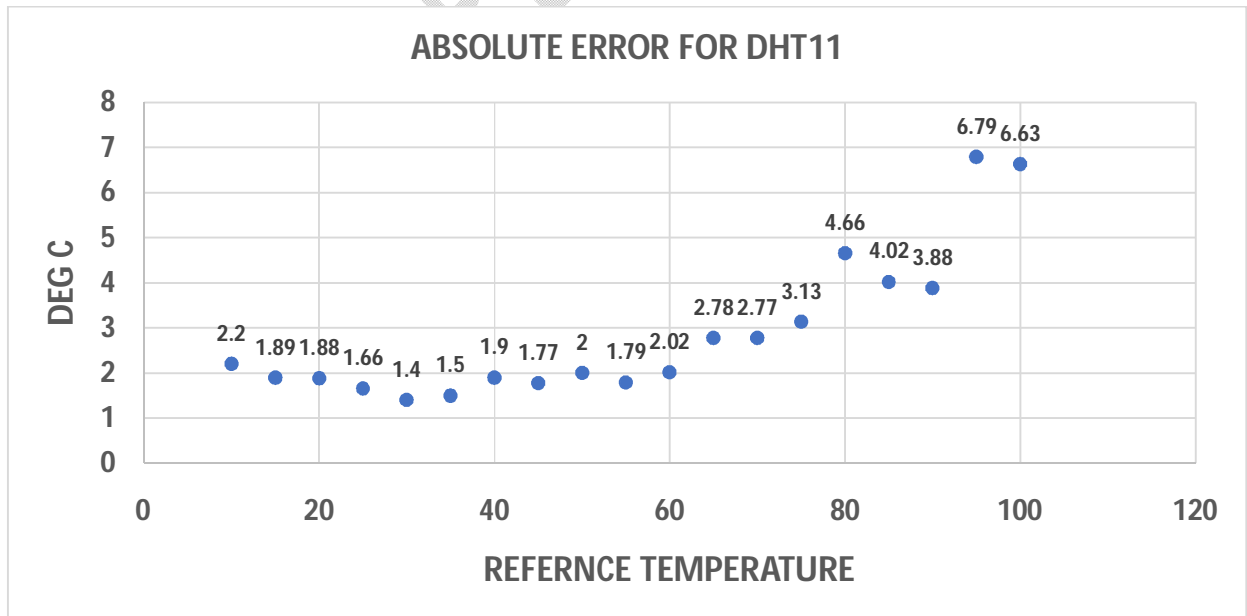

Graph 1. Absolute error of DHT11 with first method

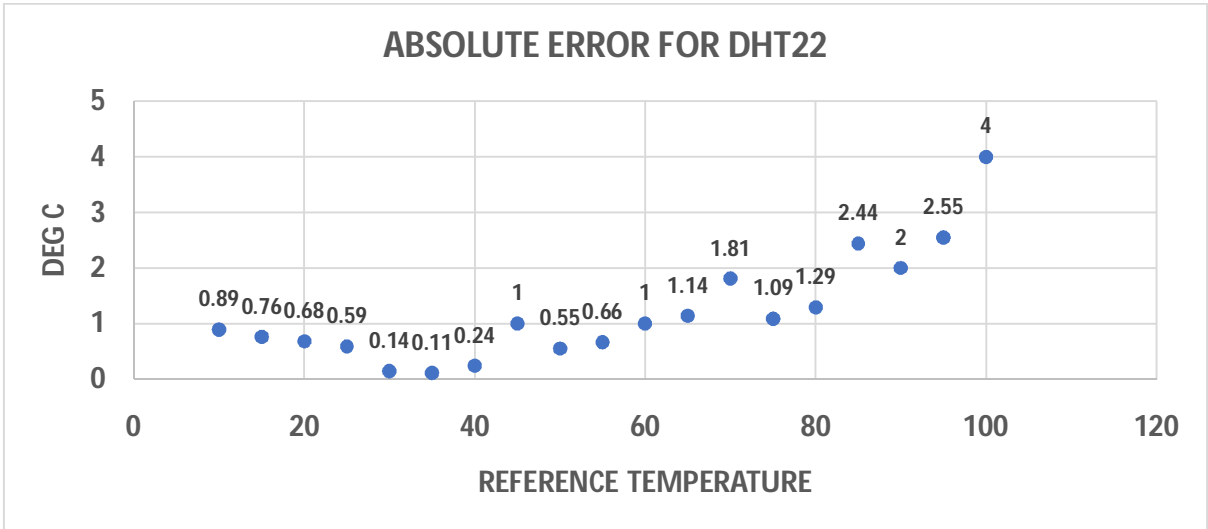

Graph 2: Absolute error for DHT22 with first method.

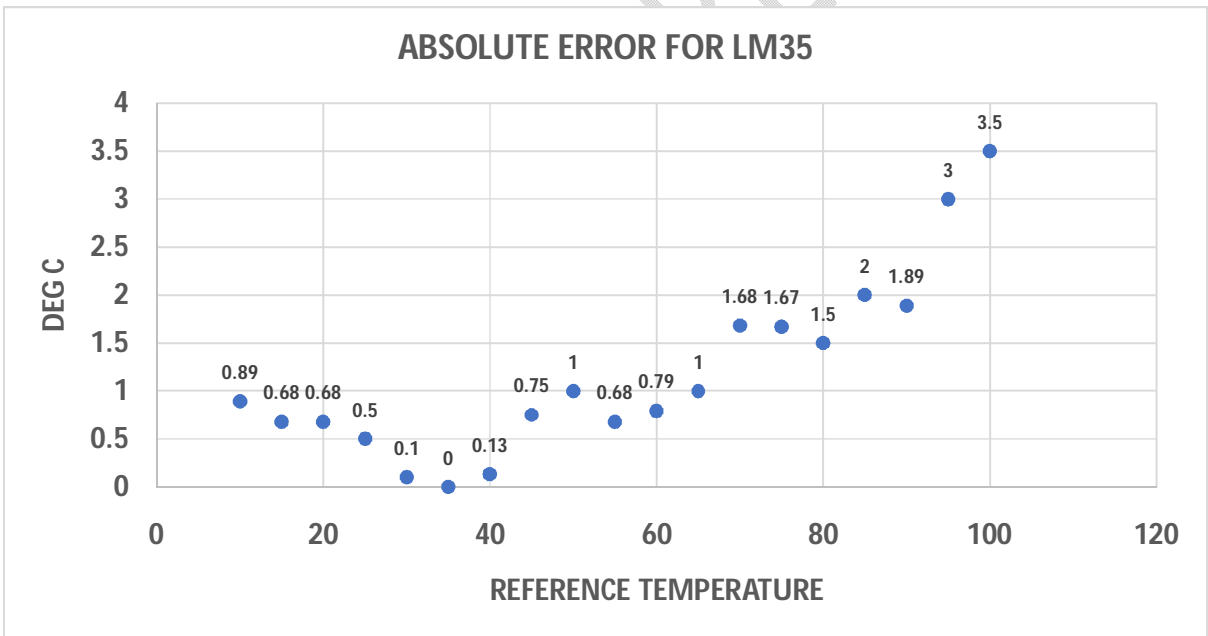

Graph 3: Absolute error for LM35 with first method.

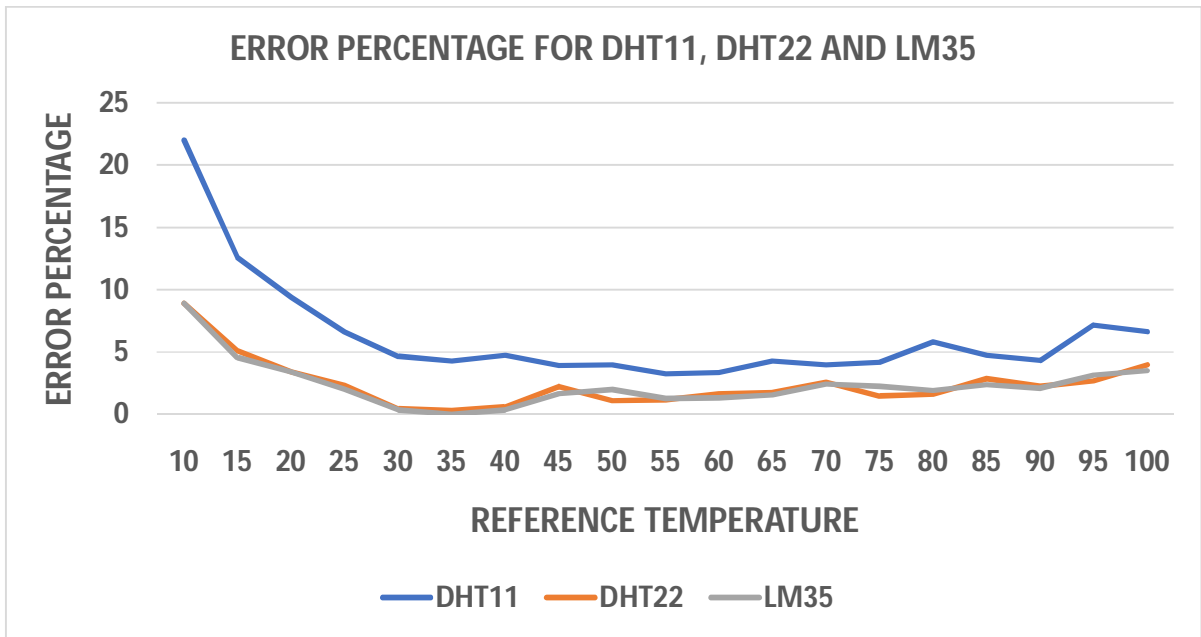

Graph 4: Comparison of error percentage of DHT11, DHT22, LM35 with first method.

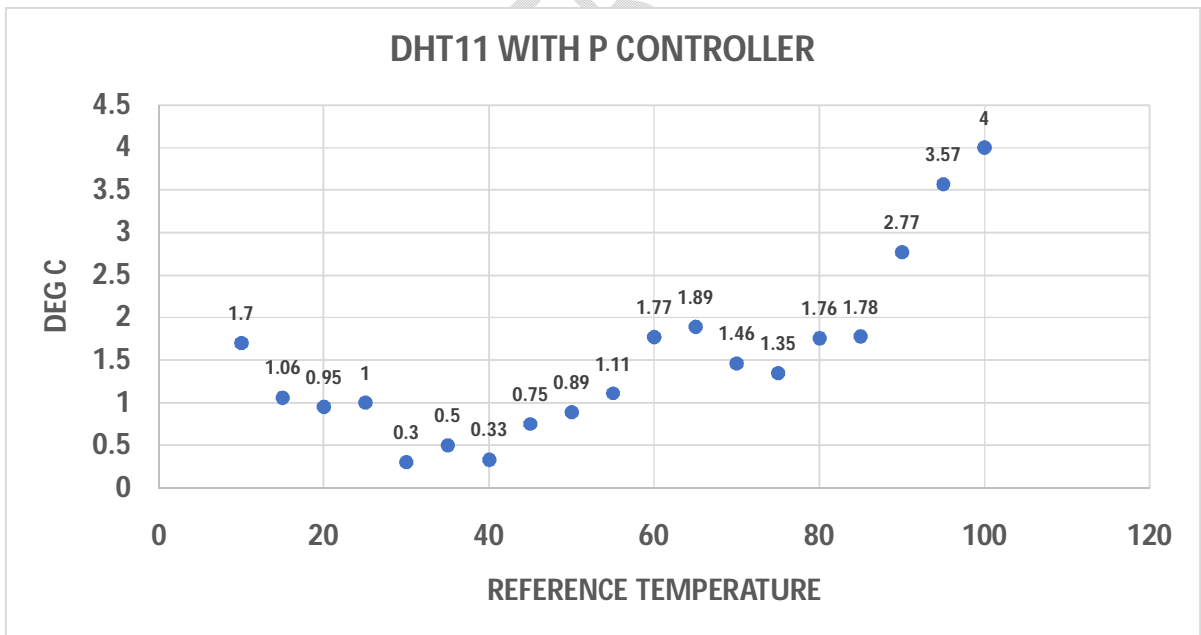

Graph 5: Absolute error of DHT11 with third method

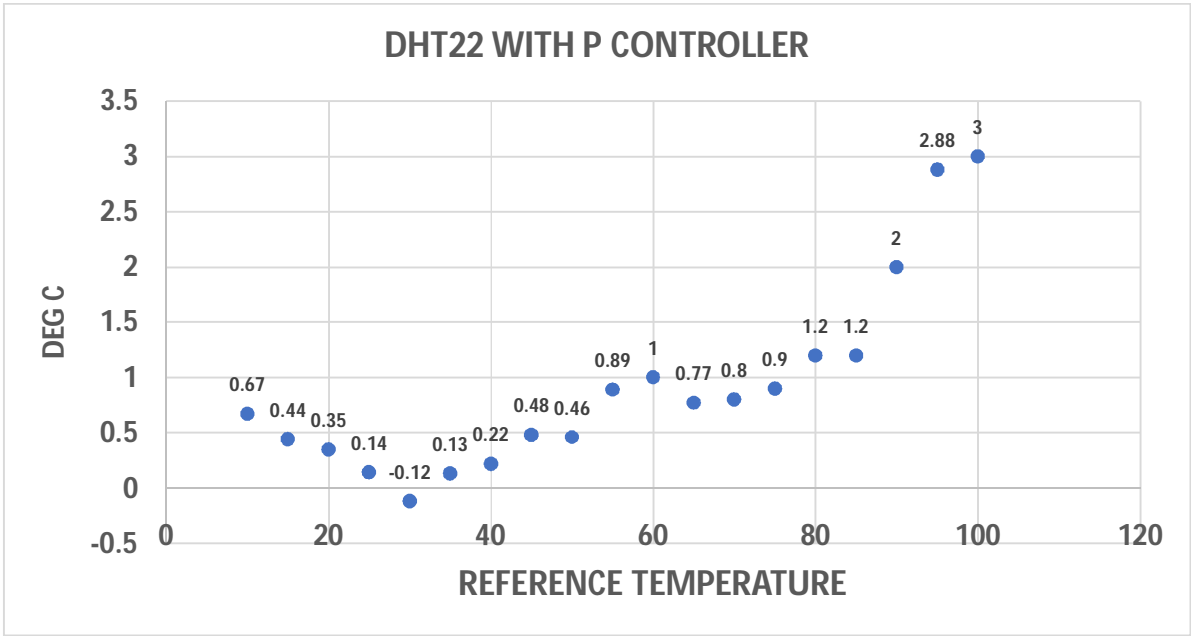

Graph 6: Absolute error of DHT22 with third method

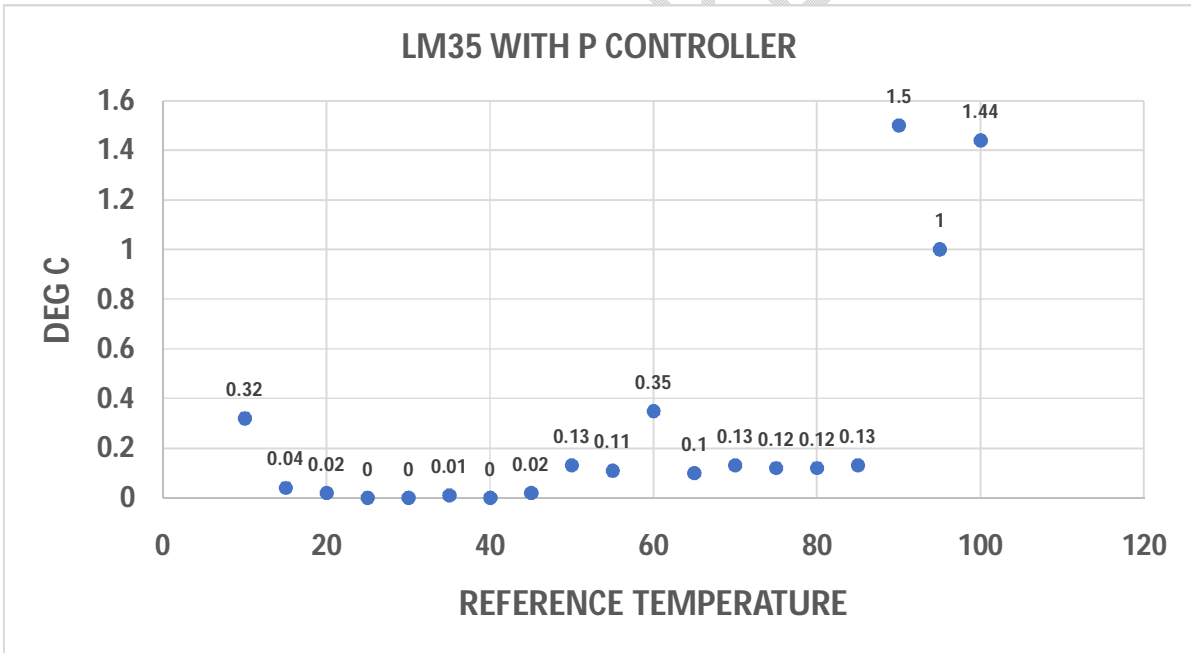

Graph7: Absolute error of LM35 with P controller in third method.

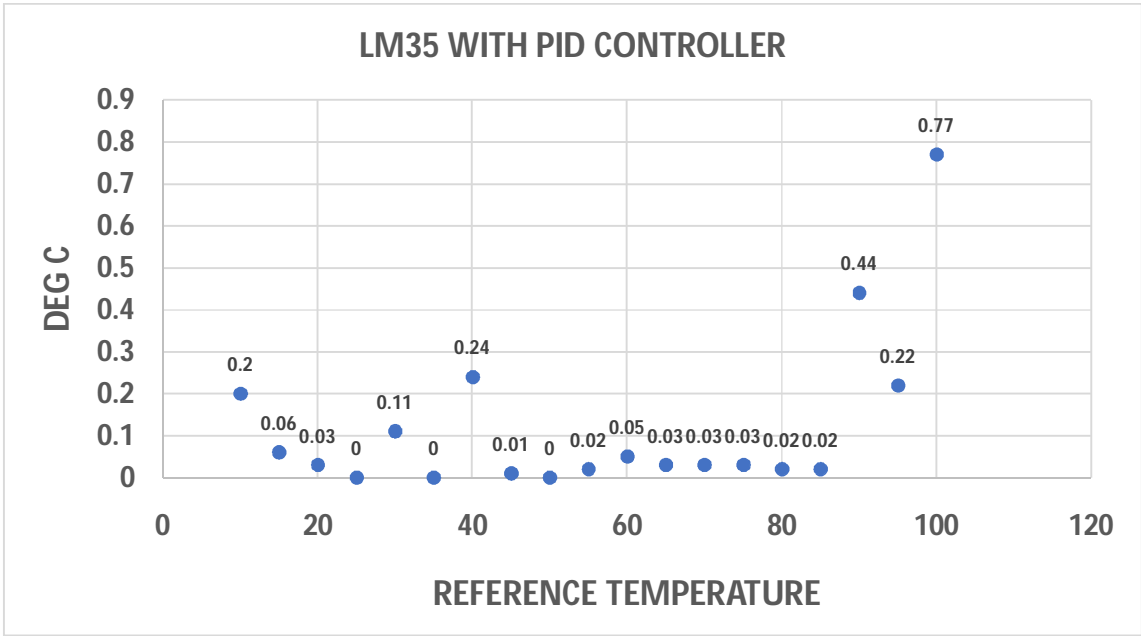

Graph 8: Absolute error of LM35 with PID controller in third method

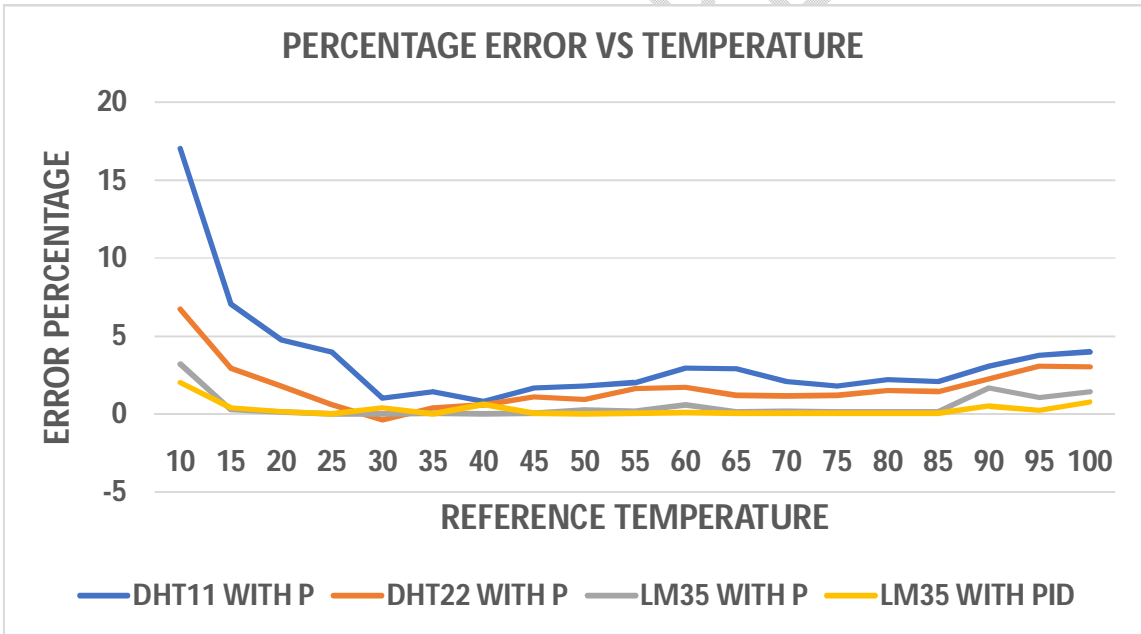

Graph 9: Comparison of error percentage of DHT11, DHT22, LM35 with P and LM35 with PID

controller in third method.



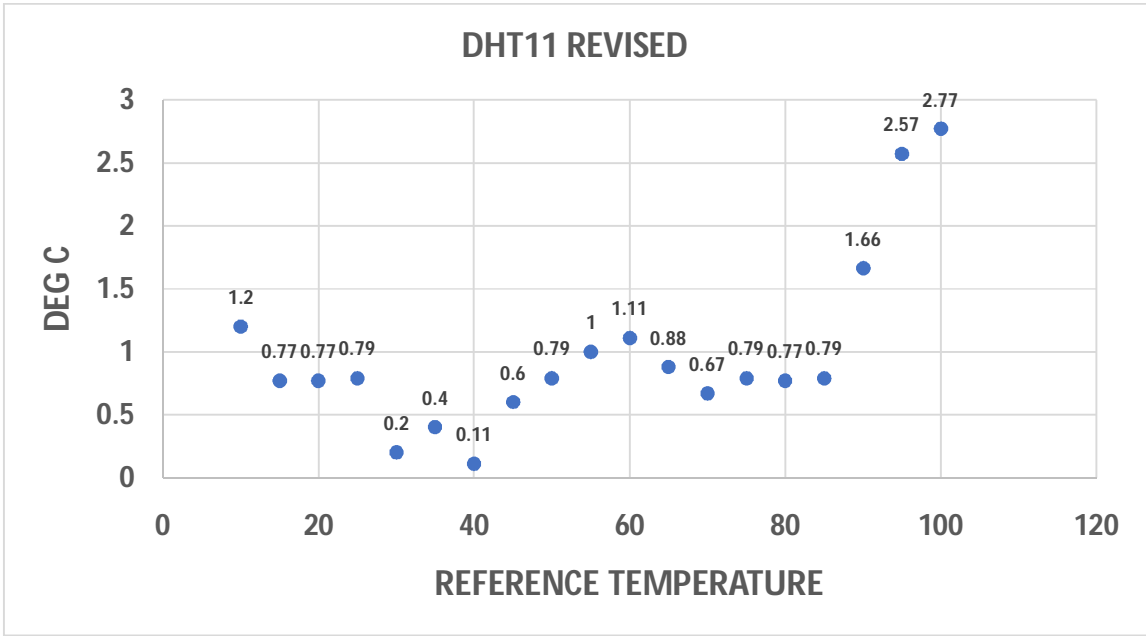

Graph 10: Absolute error of DHT11 with second method.

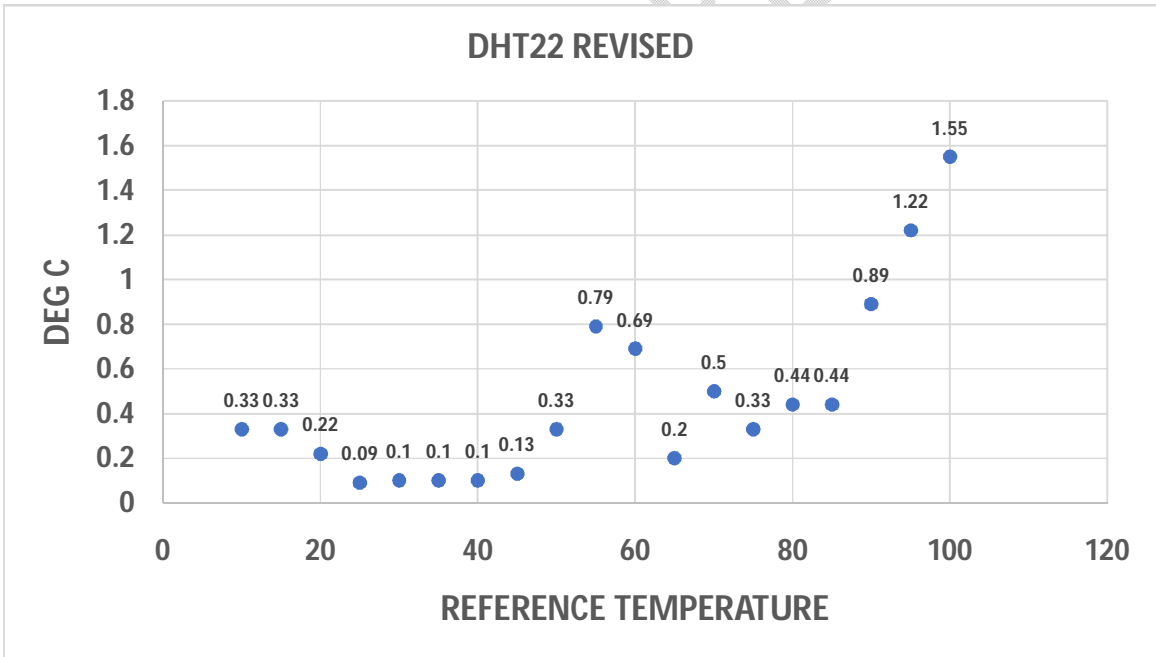

Graph 11: Absolute error of DHT22 with second method.

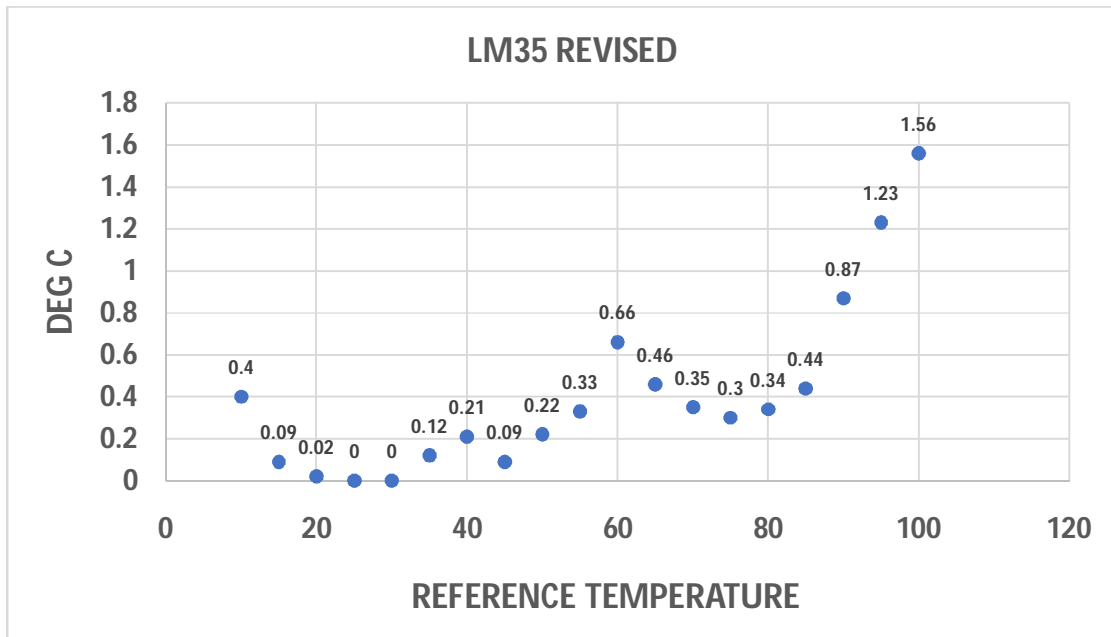

Graph 12: Absolute error of LM35 with second method

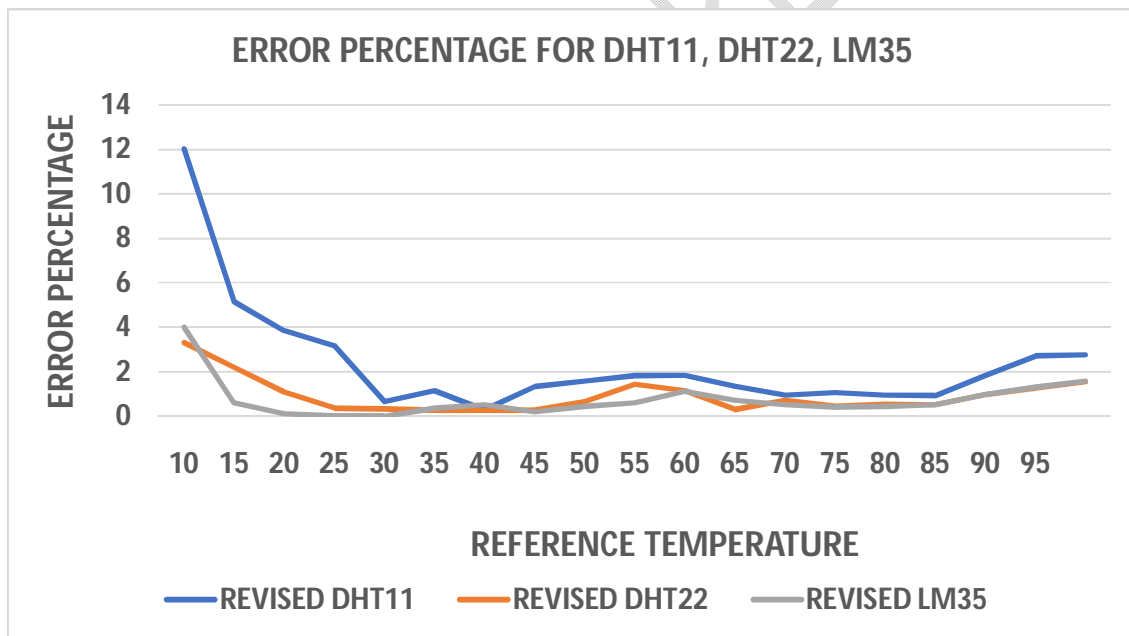

Graph 13: Comparison of error percentage of DHT11, DHT22, LM35 with third method.

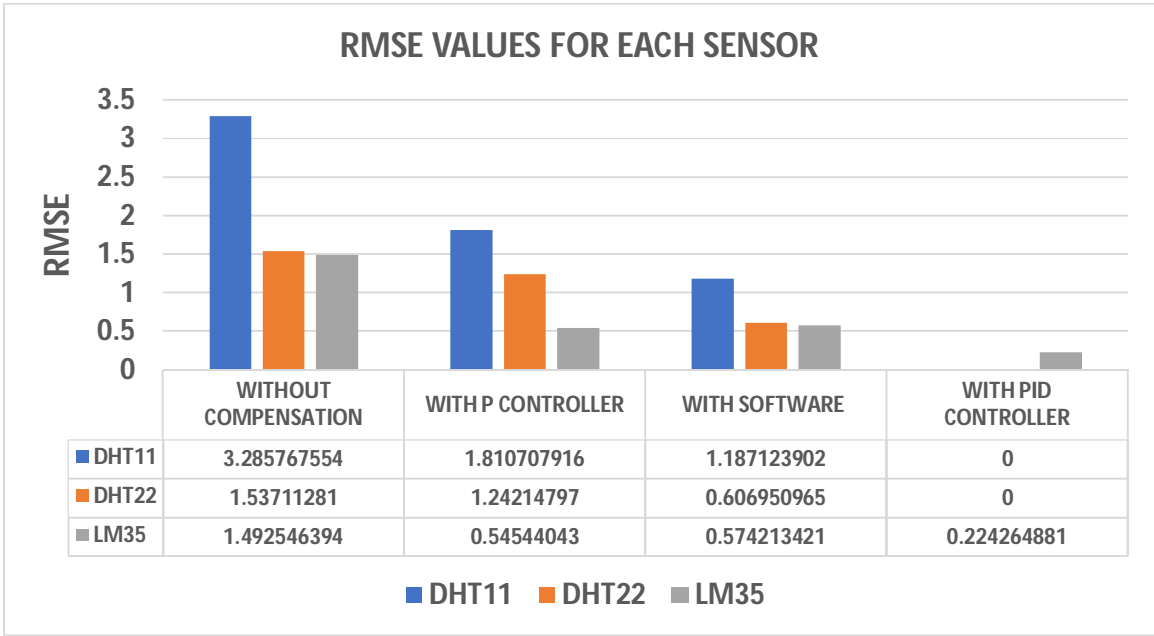

Graph 14: Comparison of RMSE values for DHT11, DHT22, LM35 sensors with and without compensation.

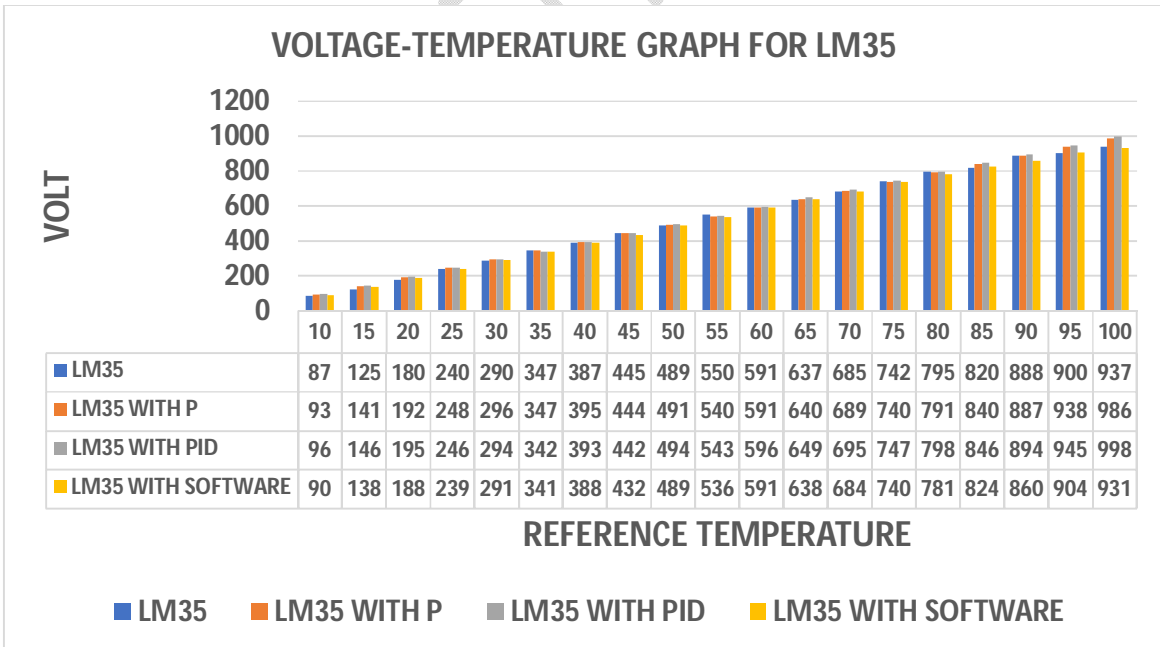

Graph 15: Voltage-Temperature sensitivity plot for LM35 with and without compensation.

1. For the first method where DHT11, DHT22 and LM35 sensors are used without temperature compensation.

- On use of DHT11 sensor for temperature measurement in the range of 10deg C to 100 deg C, the error reduces from 2.2 deg at 10 deg C reference temperature to 1.66 deg C to 1.4 deg C at 25 deg C. Which corresponds to error reduction from 22% to 6.94%.
- In the temperature range of 30 deg C to 50 deg C, the error increases from 1.4 deg C to 2 deg C, which corresponds to decrease in error percentage from 4.6% to 4%.
- In the temperature range of 55 deg C to 75 deg C, the deviation from reference value increases from 2 deg to 3.13 deg C which corresponds to gradual increase in percentage error of 4 % to 4.17%.
- When the DHT11 sensor is operated in the range of 80 deg C to 100 deg C the error in reading increases from 4.66 deg C to 6.63 deg C which is equal to percentage error of 5.8% and 6.63% respectively.
- DHT22 sensor when used for temperature measurement between the range of 10 deg to 25 deg C results in the increase of absolute error 0.89 deg C to 0.59 deg C respectively. Thus the error percentage reduces from 8.9% to 2.36 percentage at the temperature range of 10 degrees to 25 degrees C.
- DHT22 sensor shows variation of 0.14 degrees C at 30 degrees C and 0.55 degrees C at 50 degrees from the actual reading. Thus the error percentage is increased from 0.4% to 1.2% in the range of 30 degrees to 50 degrees C.
- In the range of 55 degrees C to 100 degrees C the absolute error increases from 0.66 degrees C to 4 degrees C which corresponds to increase in error percentage of 1.6% to 4%. According to the datasheet the error percentage should be 2%, which is 2 times the allowable limits of error.

- LM35 sensor when used in the range of 10 degrees C to 30 degrees C, shows absolute error of 0.89 C and 0.1 degrees C at the 10 degrees C and 30 degrees C temperature respectively. The error percentage reduces from 8.9% to 0.33%.
- When used in the range of 40 degrees to 100 degrees C, the absolute error of 0.13 degrees C at 40 degrees C and 3.5 degrees C at 100 degrees can be observed. The error percentage shows increase from 0.325% to 3.5%. According to the datasheet the error percentage should be 0.5% which shows that at 100 degrees C the error percentage is 7 times the allowable limit.
- From the observations it can be inferred that when all the three sensors are used in the permissible temperature range the error percentage is slightly higher than allowable error percentage limit. When used beyond the permissible temperature range, the error percentage increases beyond the allowable limits.

## 2. DHT11, DHT22 and LM35 used with compensation software algorithm.

- DHT11 sensor shows absolute error of 1.2 degrees C and 0.79 degrees C at 10 degrees C and 25 degrees C. Thus the error percentage is reduced from 12 % to 3.16 % in this range.
- When used in the range of 30 degrees C to 100 degrees C absolute error of 0.4 degrees C and 2.77 degrees C is been recorded. Thus the error percentage at 100 degrees C is 2.77 percentage. On using DHT11 sensor with compensation algorithm the RMSE reduces from 3.28 to 1.18.

- DHT22 sensor shows absolute error of 0.33 degrees C at 10 degrees C and 0.1 degrees C at 30 degrees C when used with temperature compensation algorithm. The error percentage also reduces from 3.3% to 0.33% in the temperature range of 10 degrees C and 30 degrees C.
- For the temperature range of 35 degree C to 100 degrees C absolute error is 0.1 degrees C and 1.55 degrees C at 35 degrees C and 100 degrees C respectively. The error percentage observed in this range is also within the allowable error percentage limits.
- LM35 sensor when used with temperature compensation algorithm, records absolute error of 0.4 degrees C and 0.12 degrees C at the temperature of 10 degrees C and 35 degrees C respectively. The corresponding error percentage at 10 degrees C and 35 degrees C are 4% and 0.34% respectively.
- When used in the temperature range of 40 degrees C to 100 degrees C, The absolute error recorded is 0.21 degrees C at 40 degrees C and 1.56 degrees C at 100 degrees C. The error percentage shows reduction from the first method, where error percentage at 100 degrees C is 3.5% and when used with temperature compensation algorithm the error percentage is 1.56% at 100 degrees C.
- For DHT22, the RMSE decreases from 1.53 to 0.6 when compared with the first method, when DHT22 sensor is used for temperature measurement without temperature algorithm. In the case of LM35 the RMSE recorded in the second method, is 0.57 as in the first method RMSE of 1.49 was observed.

### 3. DHT11, DHT22, LM35 used with P and PID controller.

- Operation of temperature measurement of DHT11 in the temperature range of 10 degrees C to 30 degrees C shows absolute error of 1.7 degrees C and 0.3 degrees C at the temperature of 10 degrees C and 30 degrees C respectively. In the temperature range of 35 degrees C to 100 degrees C the absolute error of 0.5 degrees C and 4 degrees C at 35 degrees C and 100 degrees C is observed.
- Thus the error percentage at 10 degrees C with first method 22% and with the third method it is reduced to 17%, while at 100 degrees C the error percentage was 6.63% it is reduced to 4%. The RMSE of 1.81 is recorded where it was 3.28 with the first method.
- DHT22 sensor when used for the measurement of temperature in the temperature range of 10 degrees C to 40 degrees C shows absolute error of 0.67 degrees C and 0.22 degrees C at 10 degrees C and 40 degrees C respectively. For the temperature range of 45 degrees C to 100 degrees C, the absolute error observed is 0.48 degrees C and 3 degrees C.
- The reduction in error percentage observed at 10 degree C from the first method is from 8.9% to 6.7% at 10 degrees C, while at 100 degrees the error percentage is reduced by 1% from 4% to 3%. The RMSE at the third method is found out to be 1.24 while it was 1.53 for the first method.
- LM35 with P type of controller shows absolute error of 0.32 degrees C and 0.02 degrees C at 45 degrees C. In the temperature range of 50 degrees C and 100 degrees C the absolute error recorded is 0.13 degrees C at 50 degrees C and 1.44 degrees C at 100 degrees C.

- For the error percentage at the extreme points, the first method shows error percentage of 8.9 % at 10 degrees C and LM35 with P type of controller shows 1.44% of error percentage. The RMSE is reduced from 1.49 to 0.54 as compared to the first method.
- LM35 with PID type of controller shows absolute error of 0.2 degrees C at 10 degrees C and 0.24 degrees c at 40 degrees C. While using in the temperature range of 45 degrees C and 100 degrees C, the absolute error observed at 45 degrees C was 0.01 degrees C and at 100 degrees C the absolute error observed was 0.77 degrees C.
- The error percentage reduces from 8.9% in the first method to 2% when LM35 when used with PID controller at 10 degrees C. At 100 degrees C the error percentage is reduced from 3.5% to 0.77% which is nearly 5 times reduction in the error percentage. The RMSE is reduced from 1.49 to 0.22.
- For analogue type of IC such as LM35 the voltage temperature response is also recorded and plotted. From the plot it is observed that better maintenance of slope of 10mV/degrees C is achieved using LM35 with PID controller, followed by P controller.

## **Conclusion**

The focus of research is on analyzing and comparing the performance of three temperature sensors, DHT11, DHT22 and LM35 across various temperature ranges and methods. The study demonstrates the importance of temperature compensation in enhancing the accuracy and reducing the error percentages of the sensor readings. The application of



compensating algorithm significantly reduces the RMSE and error percentages for all three sensors across all the tested temperature ranges. It can be concluded that LM35 with the PID controller exhibits the best performance in terms of error reduction and stability, achieving an RMSE of 0.22. DHT is fairly suitable for basic applications but suffers from higher error percentages at extreme temperatures, particularly when operated outside its rated range. DHT22 and LM35 better suits for more precise applications. LM35, being an analog sensor, provides high accuracy and exhibits the least error when paired with a PID controller.

### **Future scope**

In precision irrigation, accurate temperature measurements are crucial for calculating evapotranspiration for ensuring efficient water usage and minimizing environmental impacts. The temperature sensors used for this purpose needs to be cost effective too. When the low cost temperature sensors are used with compensating algorithms high precision and accuracy in temperature measurement is achieved. Integration and tuning of hardware-based PID controllers with analogue type of temperature sensor IC is difficult for realization, this can be achieved with software. Realization of P or PID type controller with software can increase the memory requirement and increase the power consumption of the

micro-controller used. Thus hybrid model of realization of compensating algorithm is required, where PID controller is designed on hardware and temperature measuring algorithm is embedded in software.

**Importance of the research:** Temperature compensation is essential for ensuring the accuracy and reliability of temperature readings. The sensor readings can be affected by factors such as changes in ambient temperature, voltage fluctuations, or sensor characteristics. Digital temperature sensors like DHT11, DHT22 have specific range and performance limits, without temperature compensation, sensor readings may drift, particularly at the edges of these ranges. Sensors can show drift over time or under varying environmental conditions, thus temperature compensations helps reducing drift ensuring stability and consistent readings. Without compensation, sensors report temperatures that are slightly in deviation from actual temperatures, compensation helps to mitigate sensor's performance in changing humidity, air pressure, and even age of the sensor. Temperature compensation may also help reduce sensor wear by keeping the sensor's output stable over long period of use, which is particularly of utmost requirement where high-precision and long term deployment is needed.

## References

- [1] B. G. Liptak, Instrument Engineers Handbook, Volume 1 Process Measurement and Analysis, CRC Press, 2002.
- [2] A. Shawney, A course in Electrical and Electronic Measurements and Instrumentation,

Dhanpat Rai and Co..

- [3] J. Knox, M. Kay and E. Weatherhead, "Water regulation, crop production, and agricultural water," *Agriculture Water Management*, pp. 3-8, 2012.
- [4] C. Hedley, J. Knox, S. Raine and R. W. Smith, "Advanced Irrigation Technologies," *Encyclopedia Agricultural food system*, pp. 378-406, 2024.
- [5] H. Turral, M. Svendsen and J. Faures, "Investing in irrigation: Reviewing the past and looking to the future," *Agriculture Water Management*, vol. 97, pp. 551-560, 2010.
- [6] A. Sarma, "Precision irrigation-a tool for sustainable management of irrigation water.," in *In Proceedings of the Civil Engineering for Sustainable Development- Opportunities and Challenges*,, Guwahati, India, 2016.
- [7] N. Shah and I. Das, "Precision Irrigation: Sensor Network Based Irrigation," *In Problems, Perspectives and Challenges of Agricultural Water Management*;, p. 217–232, 2012.
- [8] B. Leib, M. Hattendorf, T. Elliott and G. Matthews, "Adoption and adaptation of scientific irrigation scheduling: Trends from Washington, USA as of 1998," *Agriculture water management*, p. 105–120., 2002.
- [9] L. Pereira, R. Allen, M. Smith and D. Raes, "Crop evapotranspiration estimation with FAO56: Past and future," *Agriculture Water Management*, pp. 4-20, 2014.
- [10] R. Allen, L. Pereira, D. Raes and M. Smith, "FAO Irrigation and Drainage Paper No. 56;," Food and Agriculture Organization of the United Nations, Rome, Italy, 1998.

- [11] N. P. a. I. A. Ejeh, "Design and Implementation of Base Station Temperature Monitoring," *International Digital Organization for Scientific Research*, vol. 7, no. 1, pp. 53-66, 2022.
- [12] L. Barik, "IoT based Temperature and Humidity Controlling using Arduino and Raspberry Pi," *International Journal of Advanced Computer Science and Applications*, vol. 10, no. 9, 2019.
- [13] M. Ali and M. K. Paracha, "AN IOT BASED APPROACH FOR MONITORING SOLAR POWER CONSUMPTION WITH ADAFRUIT CLOUD," *International Journal of Engineering Applied Sciences and Technology*, vol. 4, no. 9, pp. 335-341, 2020.
- [14] "DATASHEET SEARCH SITE," [Online]. Available: <https://www.electroschematics.com/wp-content/uploads/2010/02/LM35-DATASHEET.pdf>.
- [15] "DFR0067 DHT11 Datasheet.pdf," [Online]. Available: [https://components101.com/sites/default/files/component\\_datasheet/DFR0067%20DHT11%20Datasheet.pdf](https://components101.com/sites/default/files/component_datasheet/DFR0067%20DHT11%20Datasheet.pdf).
- [16] "dht-932870.pdf," [Online]. Available: [https://www.mouser.com/datasheet/2/737/dht-932870.pdf?srsId=AfmBOoq9m9F0oV5ZpeEy1e7ptyvC-j9QUjf7kgYA0nzVXgn8ZgmLBO3\\_&utm](https://www.mouser.com/datasheet/2/737/dht-932870.pdf?srsId=AfmBOoq9m9F0oV5ZpeEy1e7ptyvC-j9QUjf7kgYA0nzVXgn8ZgmLBO3_&utm).
- [17] P. Waher, "Creating a sensor to measure ambient light," in *Mastering Internet of Things. Design and create your own IoT applications using Raspberry Pi3.* ,

Birmingham, Packt, 2028, pp. 31-43.

- [18] J. S. A. Jie Gu, "mization Process for Error Compensation in Machine Tools and Optimization Process for Error Compensation in Machine Tools," in *47th SME North American Manufacturing Research Conference, Penn State Behrend Erie, Pennsylvania*, 2019.
- [19] A. Devices, "Data Sheet AD823," Analog Devices, [Online]. Available: <https://www.analog.com/media/en/technical-documentation/data-sheets/AD823.pdf>.
- [20] M. Huba, S. Chamraz, P. Bistak and D. Vrancic, "Making the PI and PID Controller Tuning Inspired by Ziegler and Nichols Precise and Reliable," *sensors*, 2021.
- [21] T. Instrumentation, "DAC8775 Quad-Channel, 16-Bit Programmable Current Output and Voltage Output Digital-to-Analog Converter with Adaptive Power Management," Texas Instrumentation, February 2017. [Online]. Available: [i.com/lit/ds/symlink/dac8775.pdf?HQS=dis-dk-null-digikeymode-dsf-pf-null-ww&ts=1735017629496&ref\\_url=https%253A%252F%252Fwww.ti.com%252Fgeneral%252Fdocs%252Fsuppproductinfo.tsp%253FdistId%253D10%2526gotoUrl%253Dhttps%253A%252F%252Fwww.ti.com%252Flit%252F](https://www.ti.com/lit/ds/symlink/dac8775.pdf?HQS=dis-dk-null-digikeymode-dsf-pf-null-ww&ts=1735017629496&ref_url=https%253A%252F%252Fwww.ti.com%252Fgeneral%252Fdocs%252Fsuppproductinfo.tsp%253FdistId%253D10%2526gotoUrl%253Dhttps%253A%252F%252Fwww.ti.com%252Flit%252F)